

ACCESSOIRES

Coupling for central drive units

Hole with splined-shaft profile in accordance with DIN 5480

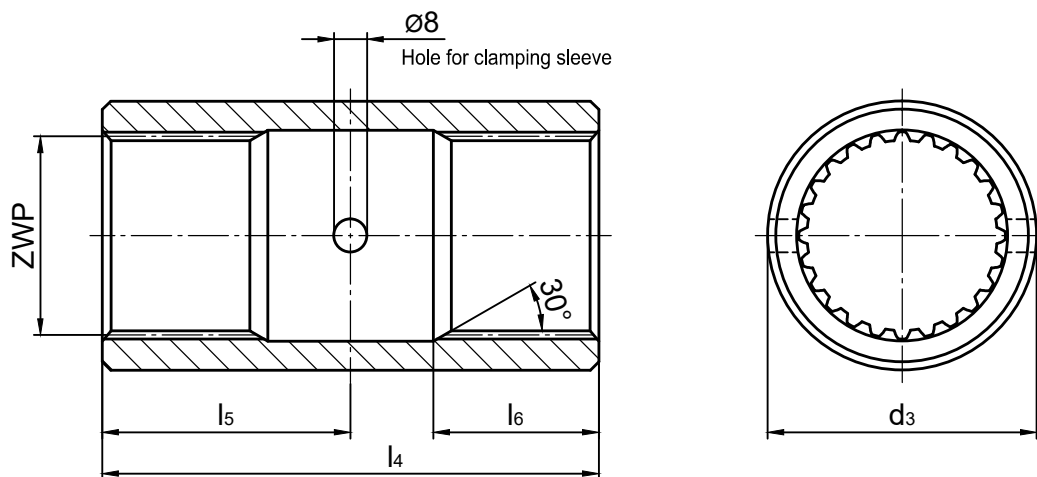

Splined-shaft profile DIN 5480 (9H)	d3	l4	l5	wl6
N 30 x 1.25 x 22	40	80	40	27.5
N 30 x 2 x 14	40	80	40	27.5
N 35 x 1.25 x 26	50	100	50	44
N 35 x 2 x 16	50	100	50	35
N 40 x 2 x 18	55	100	50	32
N 45 x 2 x 21	60	120	60	50
N 50 x 2 x 24	65	120	60	40
N 60 x 2 x 28	75	125	62.5	47.5
N 65 x 2 x 31	80	125	62.5	50
N 70 x 2 x 34	90	135	67.5	50
N 75 x 3 x 24*	95	145	72.5	52.5
N 80 x 3 x 25*	100	150	75	55
N 85 x 3 x 27*	110	160	80	57.5
N 90 x 3 x 28*	115	170	85	60

* available on request

ACCESSOIRES

Cellular plastic buffer for wheel block RB 160 – 400

Buffer made from cellular polyurethane with large energy capacity for operating temperatures of -20 °C to $+80\text{ °C}$.

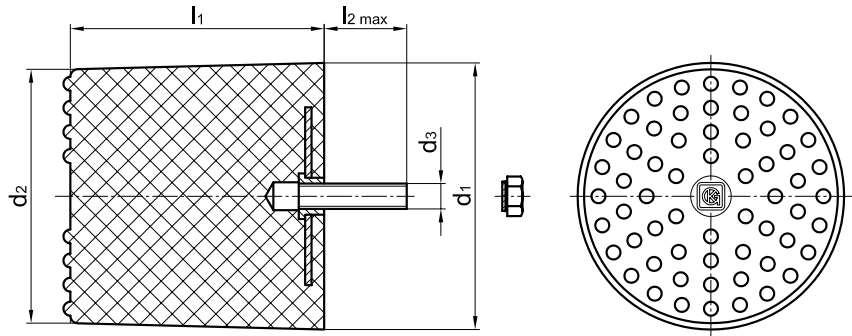

Holes are available on the wheel block for mounting the buffer. Attachment is by means of a grub screw in the buffer and a retained nut, which is drawn into the wheel block housing.

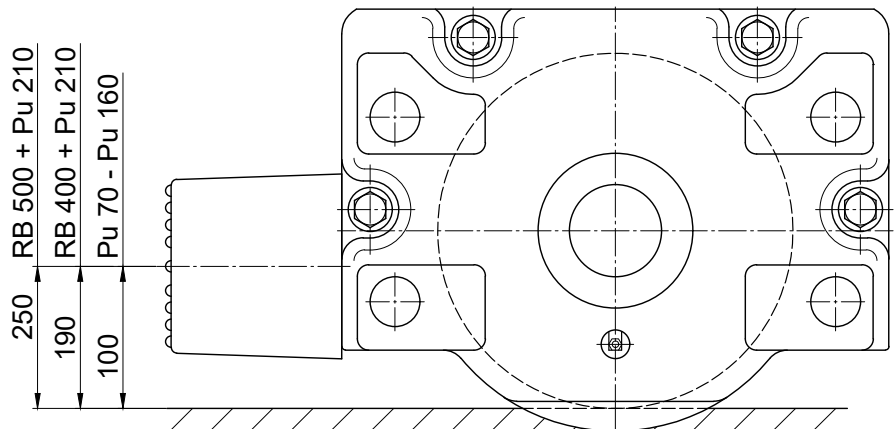

Nominal size	d1	d2	l1	d3	l2	Energy-absorption [kJ] ²⁾	Spring-travel [mm] ¹⁾	Final force [kN] ¹⁾	Wight per unit [kg]	for wheel block
Pu 70	70	65	66	M 12	28	max. 0.9	46	18	0.4	RB 160 RB 200
Pu 100	100	95	100	M 12	33	max. 2.6	70	27	0.8	RB 160 RB 200 RB 250
Pu 130	130	122	120	M 12	43	max. 5.1	84	45	1.2	RB 200 RB 250 RB 315
Pu 160	160	155	150	M 12	43	max. 9.2	105	95	1.8	RB 250 RB 315
Pu 210	210	200	200	M 20	65	max. 20.0	140	120	4.1	RB 400 RB 500

1) These values apply to impact forces, which occur during crane operation ($V = 120\text{ m/min}$)

2) $V = 240\text{ m/min}$

Ordering example

Cellular plastic buffer Pu 130

Included in the scope of delivery:

- 1 Cellular plastic buffer
- 1 Grub screw
- 1 Retained nut

CELLULAR PLASTIC BUFFER FOR WHEEL BLOCK RB 160 – 400

Diagrams

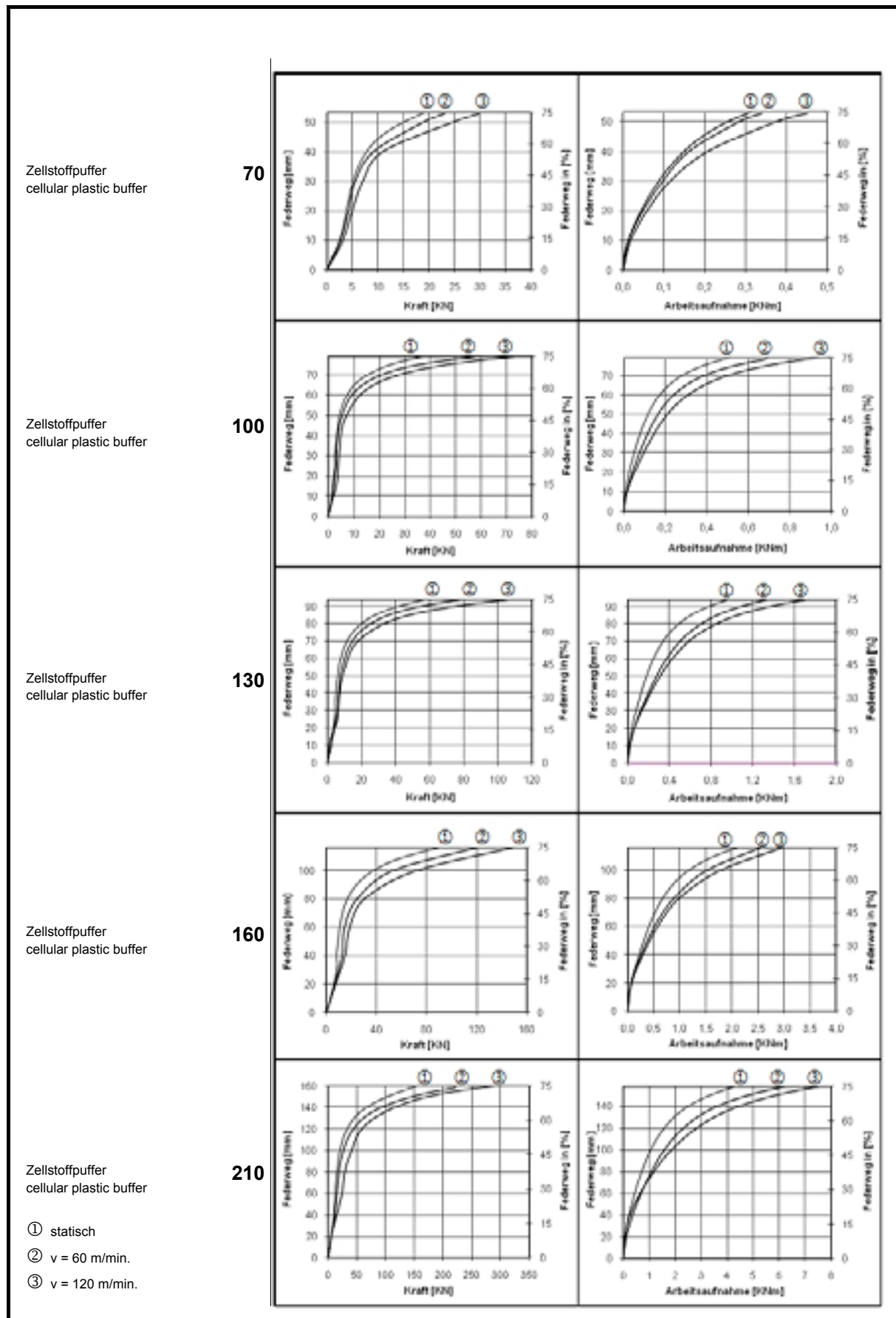

ACCESSOIRES

Cellular plastic buffer for wheel block with horizontal roller guide RB 250 – 400

Buffer made of cell polyurethane with a large working capacity for operating temperatures of - 20 °C to +80 °C.

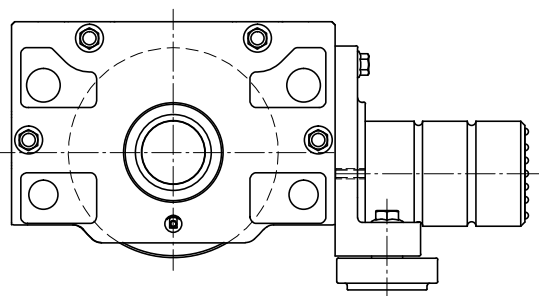
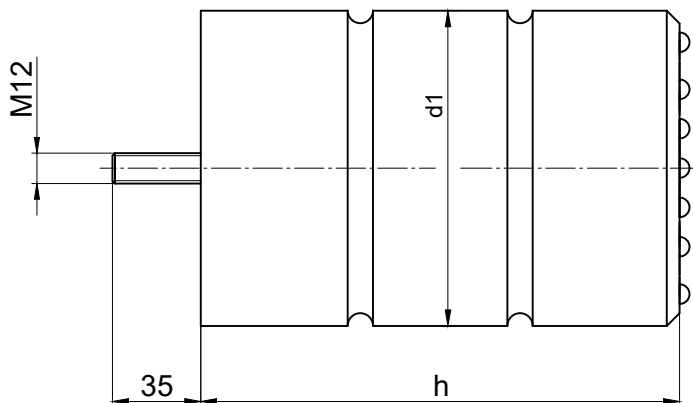
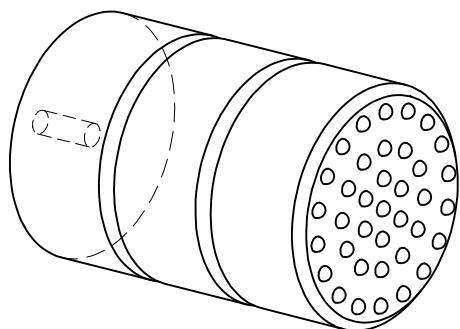

Nominal size d1 x h	Energy-absorption [kJ] ¹⁾	Spring travel [mm] ¹⁾	Final force [kN] ¹⁾	Weight per unit [kg]	for wheel block
125 x 190	8.6	143	125	1.32	RB 250
160 x 240	18	180	200	2.66	RB 315
200 x 300	35	225	310	5.1	RB 400

Wheel block with guide roller

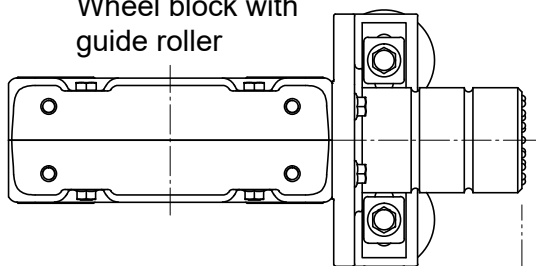

Wheel block with spacer disc

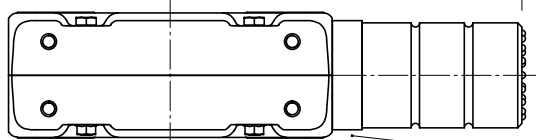

The installation of the cellular plastic buffer on the horizontal roller guide is possible without spacer discs.

Parallel operating wheel blocks without horizontal roller guide can be installed with spacer discs for length compensation (see fig.).

1) These values apply to hits, such as those occurring during crane operation

Ordering example

Cellular plastic buffer 125 x 190

Included in the scope of delivery:
1 Cellular plastic buffer with threaded pin

CELLULAR PLASTIC BUFFER FOR WHEEL BLOCK WITH HORIZONTAL ROLLER GUIDE RB 250 – 400

Diagrams

Cellular plastic buffer 125 x 190

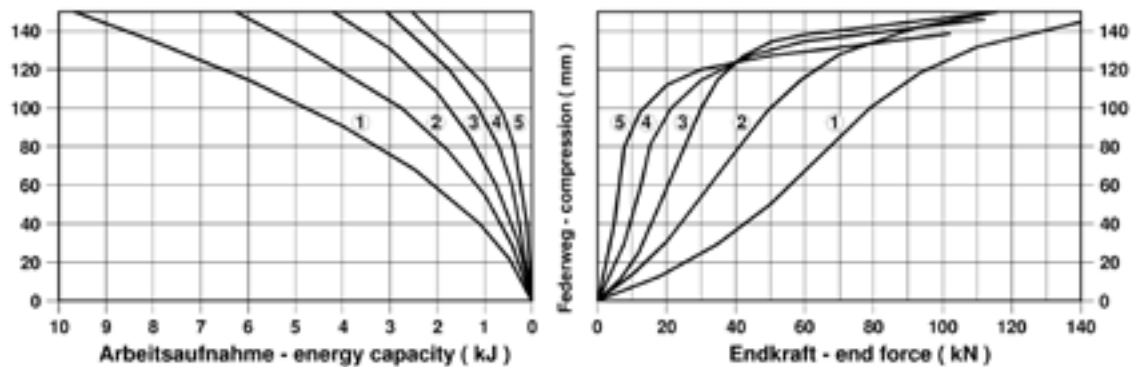

Cellular plastic buffer 160 x 240

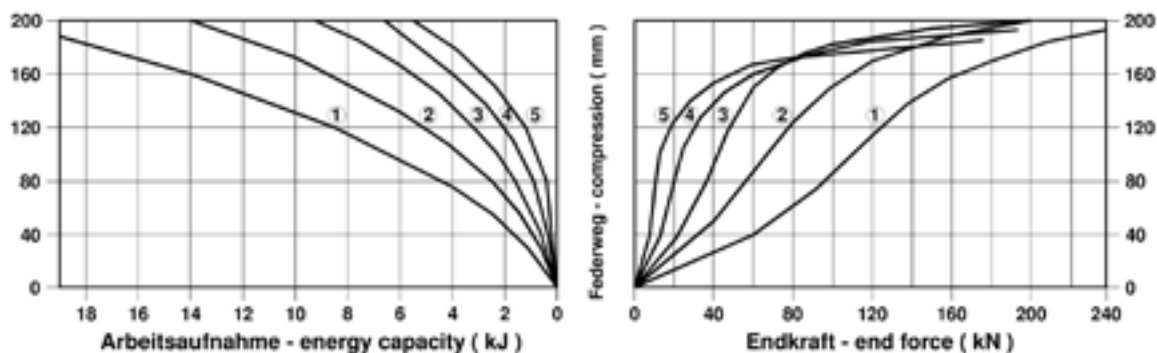

Cellular plastic buffer 200 x 300

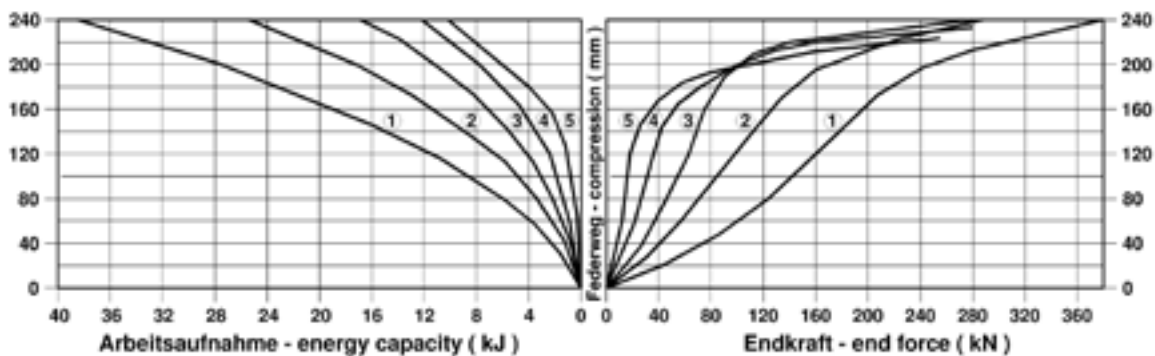

Impact velocities

- ① v = 4 m/s
- ② v = 3 m/s
- ③ v = 2 m/s
- ④ v = 1 m/s
- ⑤ Static

ACCESSOIRES

Rail cleaning system für Wheel block RB 160 – 400

The in height-adjustable rail cleaning system is supplied mounted on the wheel block. The ledge brush, with fibres made of brass wire, is arranged at an angle to discharge dirt on the side of the rail.

The installation of a cellular plastic buffer is possible by using additional spacer discs.

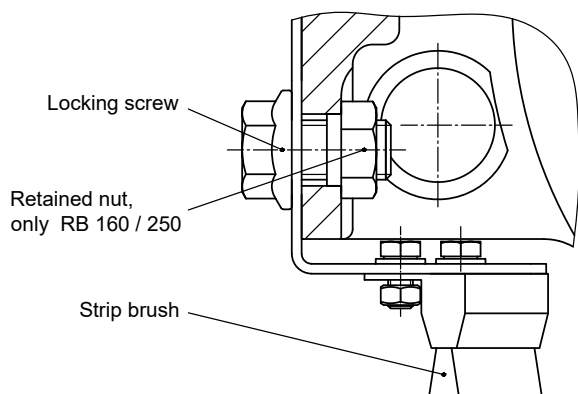

Bottom view (cutout)

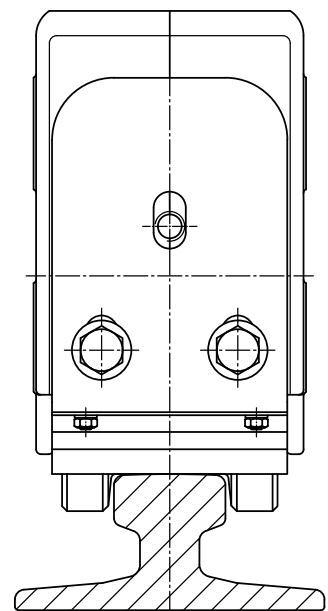
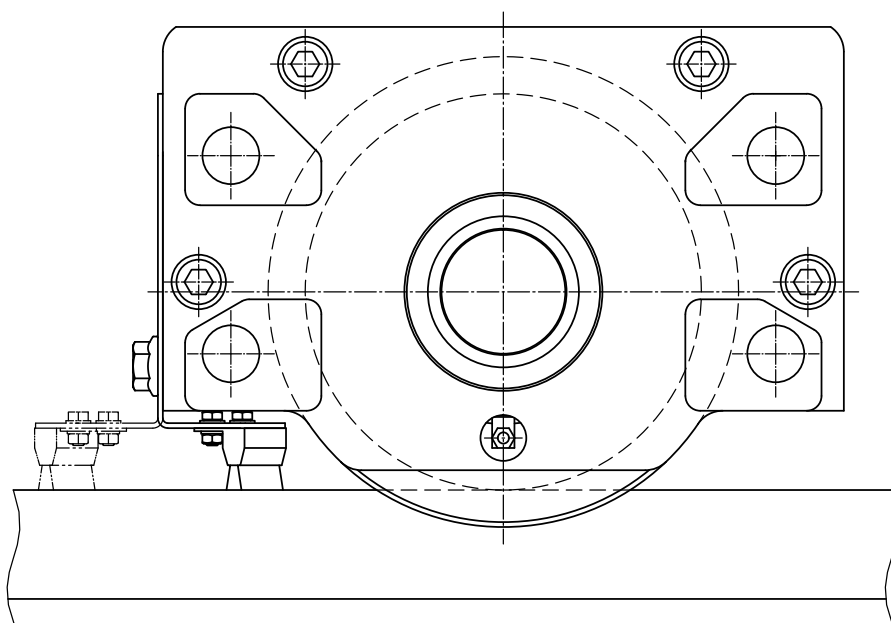
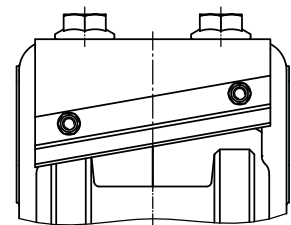

ACCESSOIRES

Rail guard for wheel block RB 160 – 400

The rail guard can be machined according to Karl-Georg or customer drawings.
The desired gap width must be specified when ordering.

The installation of a cellular plastic buffer is possible by using additional spacer discs.

