

ATLAS WHEEL BLOCK SYSTEM RB 315

Horizontal roller guide for wheels of $\varnothing 315$ (Form 1-5)

Horizontal roller guide with adjustable guide rollers made of 42CrMo4+QT.

The installation of a cellular plastic buffer (page 144) is possible without spacer discs. Parallel operating wheel blocks without horizontal roller guide can be installed with spacer discs for length compensation (see fig.).

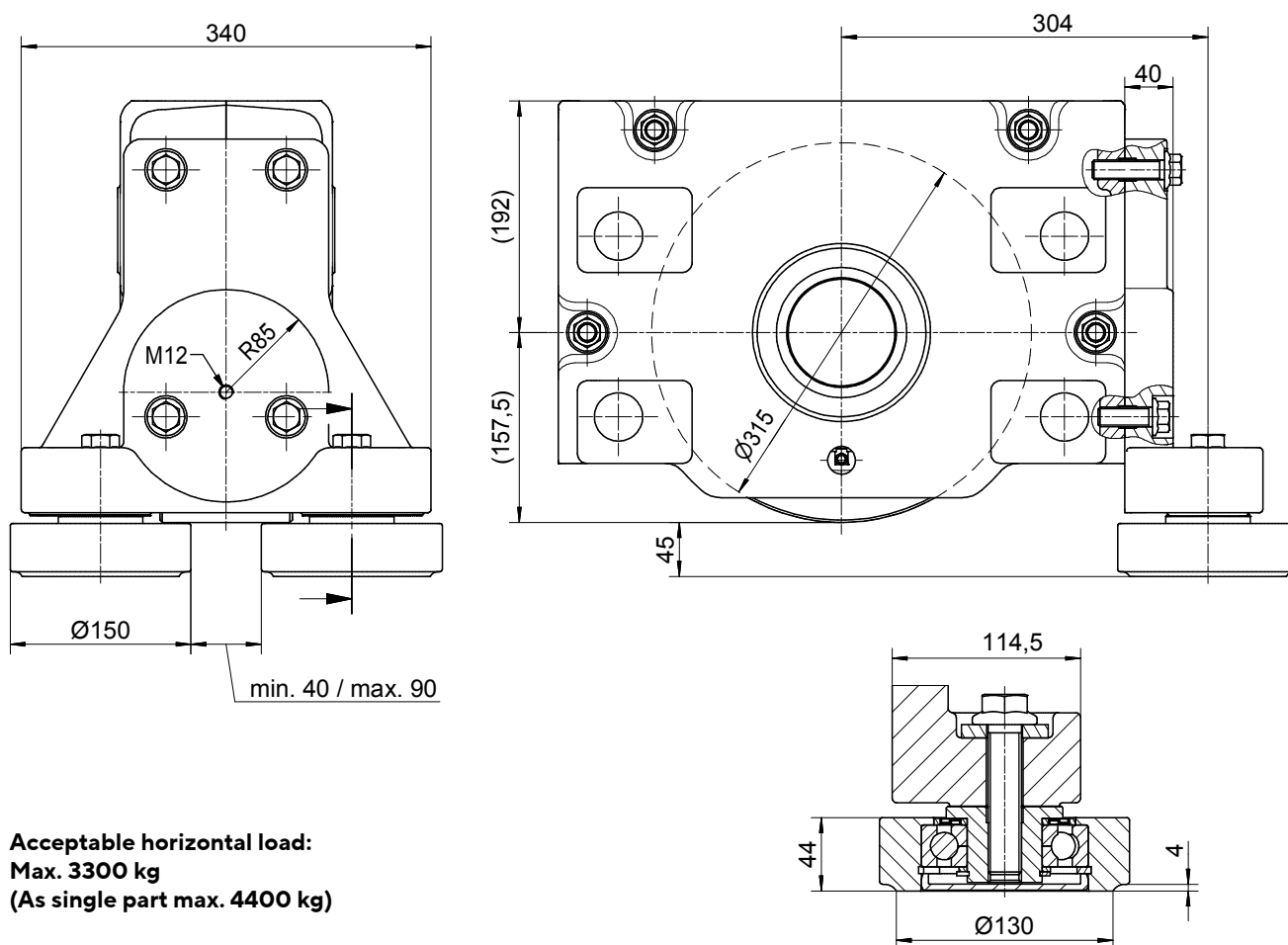

Acceptable horizontal load:
Max. 3300 kg
(As single part max. 4400 kg)

All necessary fastening elements are included in the scope of delivery.

Horizontal roller guide for other rail profiles are available on request.