

Rope Pulleys

Form D with plain bearings

DIN 15417

Design:

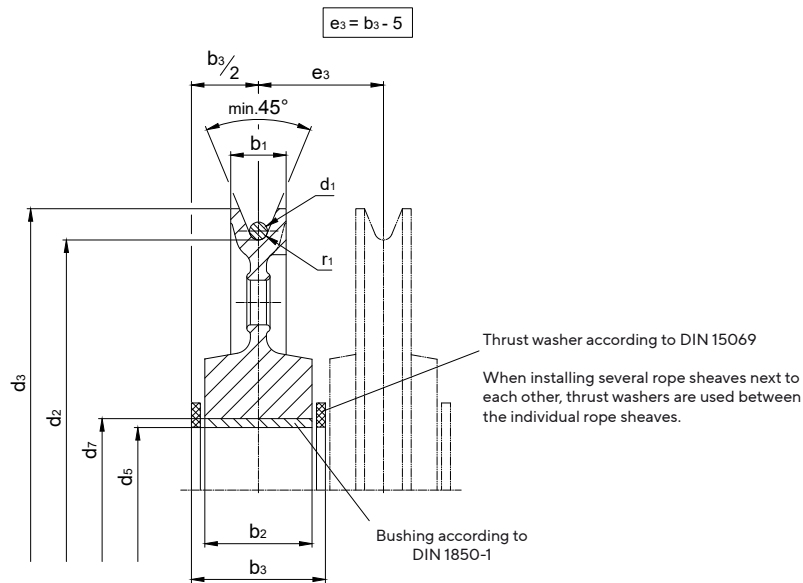

Designation of a rope pulley of $d_2 = 500$ mm and $r_1 = 10.5$:

Rope pulley 500 x 10,5 DIN 15417

Grooved profile (r_1) according to DIN 15061 part 1

Materials sheave: cast steel GS-60 or GS-42CrMo4 forged from C45, C60 or 42CrMo4 on request with hardened rope groove *no welded version made of St52*

Materials plain bearing: G-CuSn7ZnPb (Rg7)

Application	Dimensions								
	d2	r1	d1	d3	d5	d7	b1	b2	b3
2 - sheaves bottom hook block	225	4,8	9	260	45	55	32	78	100
	280	6	11	320	55	65	38	88	110
	315	7	13	360	60	75	44	88	110
	355	7,5	14	405	70	85	48	88	110
	400	8,5	16	455	75	90	52	108	130
	450	9,5	18	510	80	95	60	108	130
	500	10,5	20	570	90	105	62	118	140
	560	12	22	630	100	120	70	128	150
	630	14	26	710	110	130	72	138	160
	710	15	28	790	120	140	80	138	160
	800	17	32	890	130	150	90	138	160
900	19	36	1010	140	160	100	138	160	
4 - sheaves bottom hook block	560	10,5	20	630	140	160	62	120	140
	630	12	22	700	150	170	70	130	150
	710	14	26	790	170	190	72	140	160
	800	15	28	880	180	200	80	150	170
	900	17	32	990	200	220	90	160	180
	1000	19	36	1110	220	250	100	160	180
	1120	21	40	1240	240	270	112	190	210
	1250	24	44	1380	260	290	125	190	210

Other materials and dimensions on request.