

Wheel block

RB 250

Wheel block RB 250

Primary dimensions

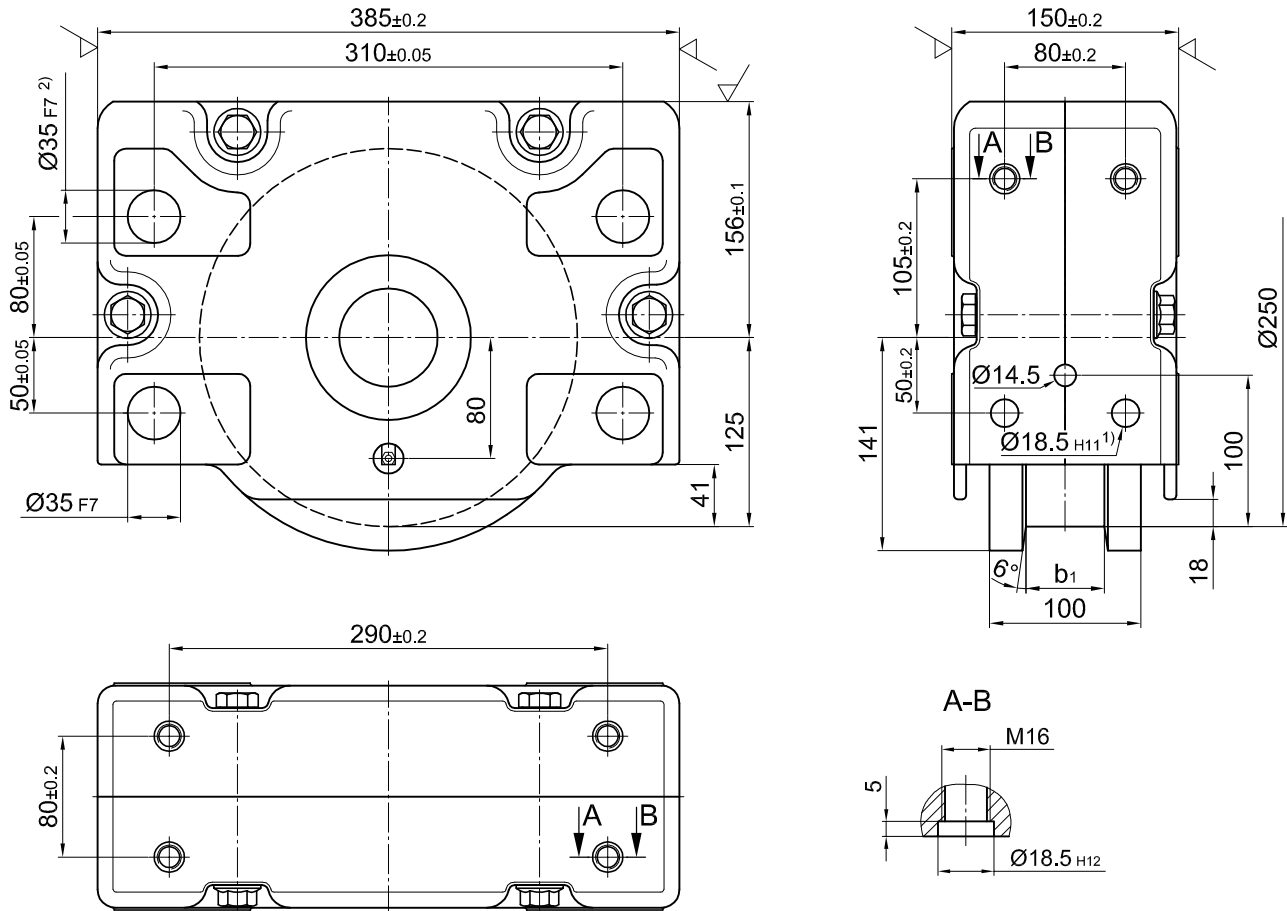

1) Due to the use of retained nuts M16 in the holes $\varnothing 18.5$ H11, the threaded connection are attained as in section A-B

2) Available with hole $\varnothing 40$ F8

Weight: ca. 52 kg
max. wheel load: 12 800 kg

Ordering examples

RBA 250×65

Wheel block 250, driven, with internal taper, with two-sided wheel flange, Design Form 1, running tread 65 mm

RBN 250×65

Wheel block 250, non driven, without internal taper, with two-sided wheel flange, Design Form 1, running tread 65 mm

RBA 250×100

Wheel block 250, driven, with internal taper, without wheel flanges, Design Form 4

RBA 250

Wheel block 250, driven, with internal taper, with Vulkollan-binding, Design Form 8

Design RBA and RBN refer to Page 5

Wheel block RB 250

Standard models

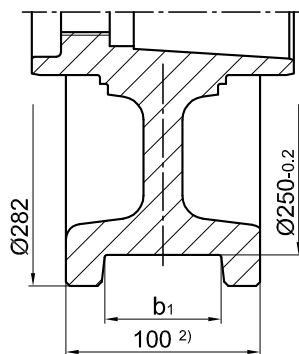

Form 1
two-sided wheel flange

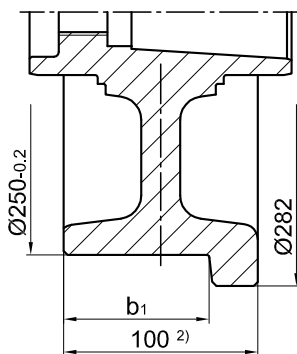

Form 2¹⁾
one-sided wheel flange
on the drive side

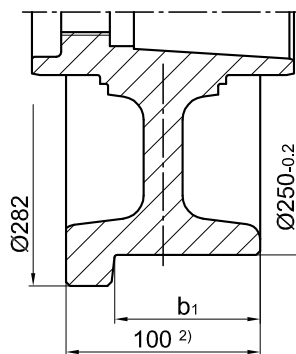

Form 3¹⁾
one-sided wheel flange
opposite to the drive side

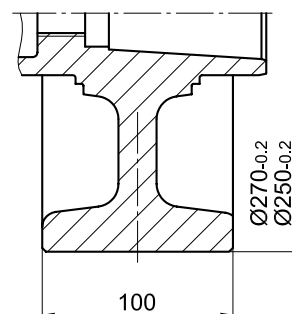

Form 4
no wheel flanges with
cylindrical running surface

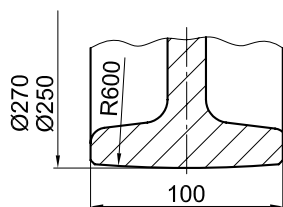

Form 5
no wheel flanges with
spherical running surface

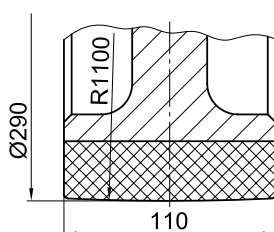

Form 6
with coating
of PA 12 G

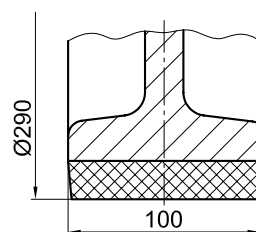

Form 7
with coating
of Vulkollan

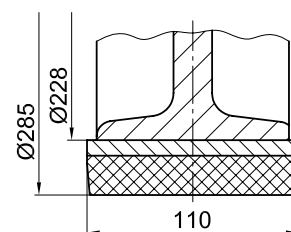

Form 8
with binding
of Vulkollan

Special models

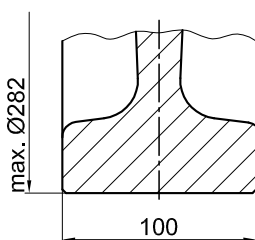

Form 9
no wheel flanges

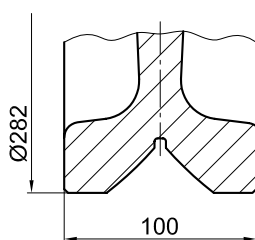

Form 10
with prismatic guide

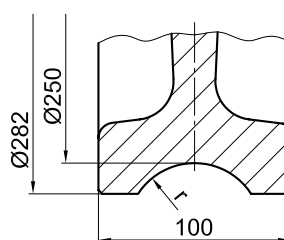

Form 11
with concave groove
 $r = 1,1 \times \text{track radius}$
(recommended)

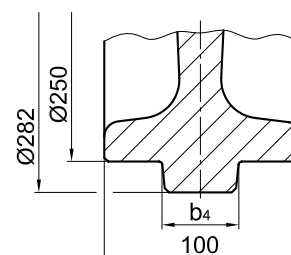

Form 12
with middle wheel flange

Form 1			Form 2 and 3	
Running tread b_1 or two-sided wheel flange			Running tread b_1 or one-sided wheel flange	
minimal	maximal	Standard	minimal	maximal
20	75	65, 75	60	87,5

1) Forms 2 and 3 are identical for the non-driven wheel block RBN

2) Available as special design with wheel width 110 mm.

Wheel block RB 250

Connection options

Top connection KA 250.1

Precisely fitted direct attachment as bolted connection (welded construction, roll section, etc.)

Top connection using locking screws for installation in accurately drilled connecting constructions. No adjustment of the wheel blocks is required.

1 Set KA 250.1 comprising of:

- 4 Locking screws M16×45 – 10.9
- 4 Locking pins 18,5×1×14

Mounting parts for larger steel plate thicknesses and/or adjustable direct connection are available on request.
For the directional version refer to the pattern of drilling KA 250.2 (Page 64).

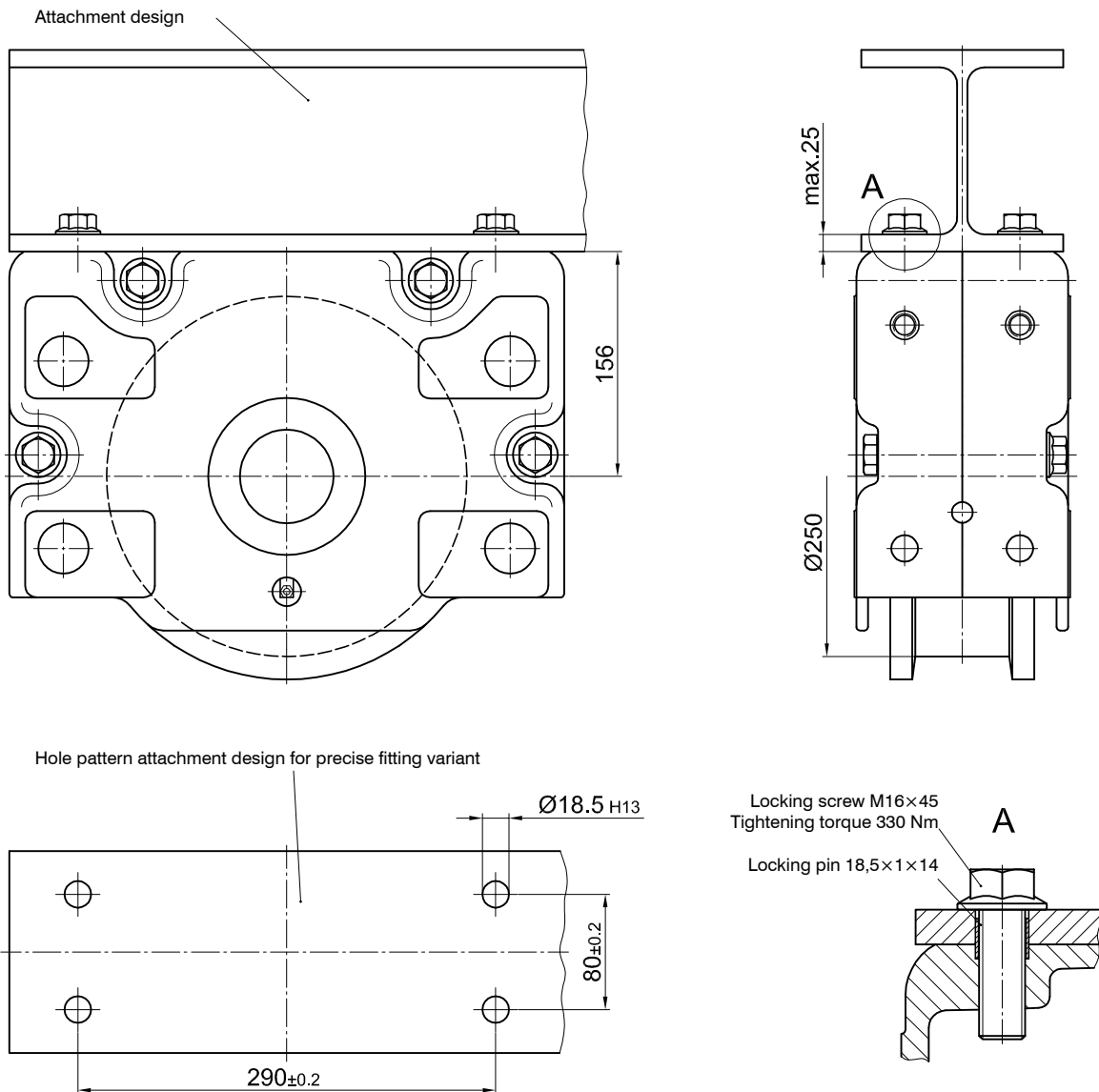

Wheel block RB 250

Connection options

Top connection KA 250.2

Precisely fitted or adjustable direct attachment as bolted connection (welded construction, roll section, etc.)

Top connection using locking pins for installation in attachment design with precisely or larger drilled attachment holes. For larger drilled attachment holes, the wheel block must be aligned. Subsequently, the wheel block is attached by bolts and should be drilled with the locking pins 8×24 supplied. However, this shouldn't be done in the area of the attachment bolts [1]). Alignment is not required for precisely drilled attachment holes.

1 Set KA 250.2 comprising of:

- 4 Grub screws M16×105 - 10.9 ZT
- 4 Safety nuts M16-10 DIN EN ISO 7042 (DIN 980)
- 4 Discs 17 DIN 6340
- 4 Locking pins 8×24 DIN EN ISO 8752 (DIN 1481), for adjustable connection
- 4 Locking pins 18,5×1×14, for precise connection

Longer locking pins are available for thicker plates.

Attachment design

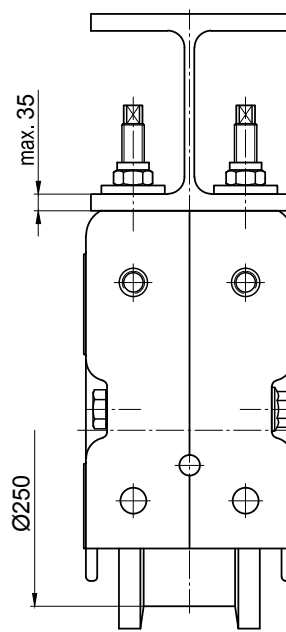
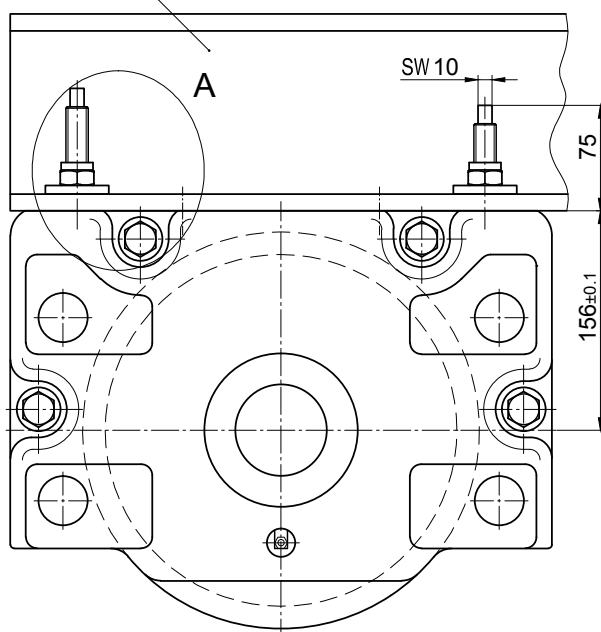

Hole pattern for the attachment design for adjustable variant

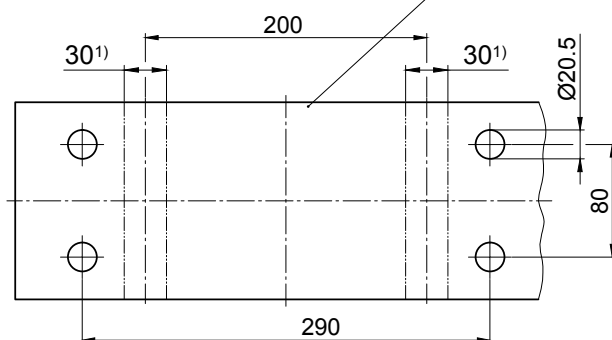

Detail A

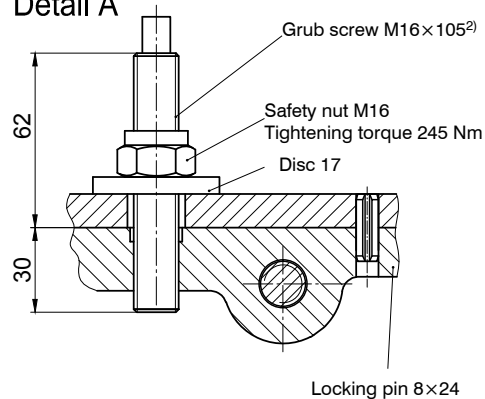

1) Pinning is not permitted in this area !

2) Can be factory-glued in the wheel block housing on request

Wheel block RB 250

Connection options

Pin attachment BA 250.1

Pin attachment is adapted to the installation in hollow profiles, floating levers, etc. by means of adjusting washers.

Pin attachment with alignment option using adjusting washers. Alignment option by replacing the adjusting washers only in dismantled condition..

1 Set BA 250.1

- 2 Bolts $\text{Ø}35\text{h}8$
- 4 Circlipse $35 \times 1,5$ DIN 471
- 4 Spacer bolts
- 24 Adjusting washers $35 \times 45 \times 0,5$ DIN 988

Pin connections are available in special design according to the customer drawing.

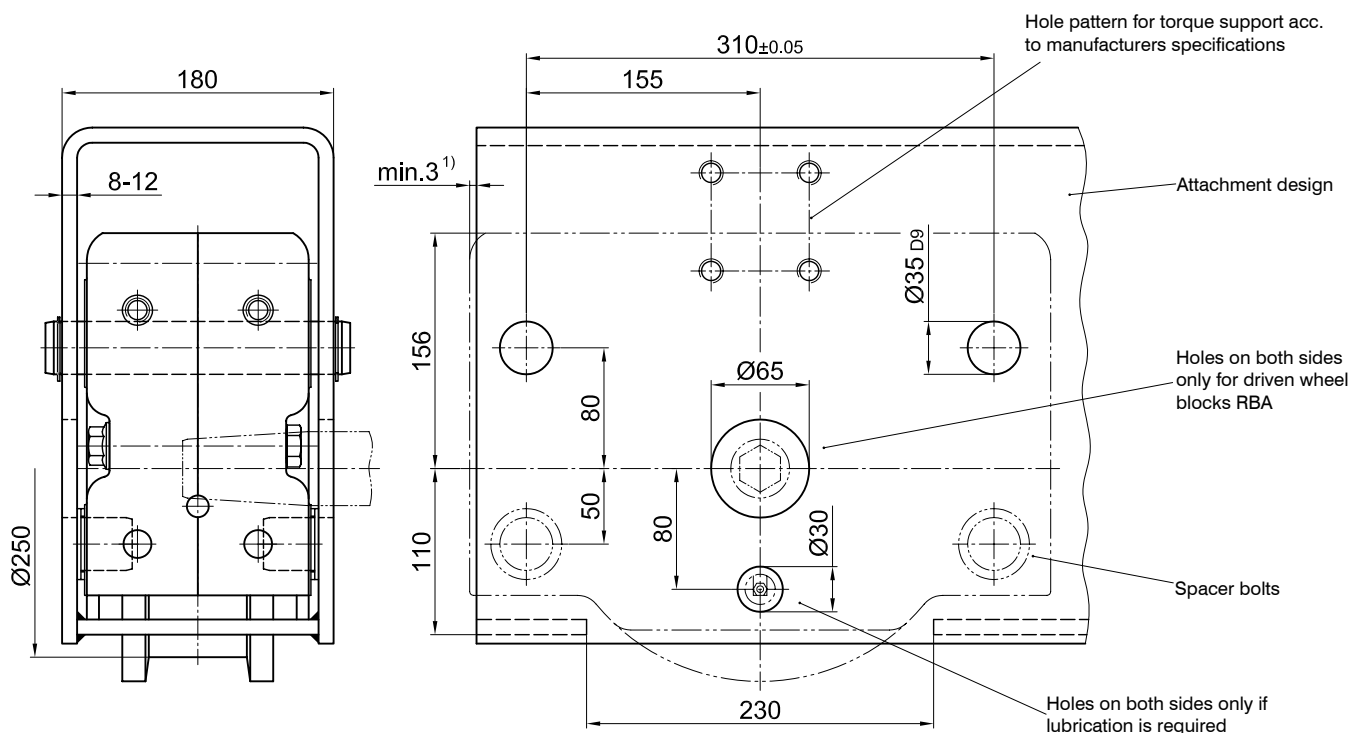

Upper suspension mounting

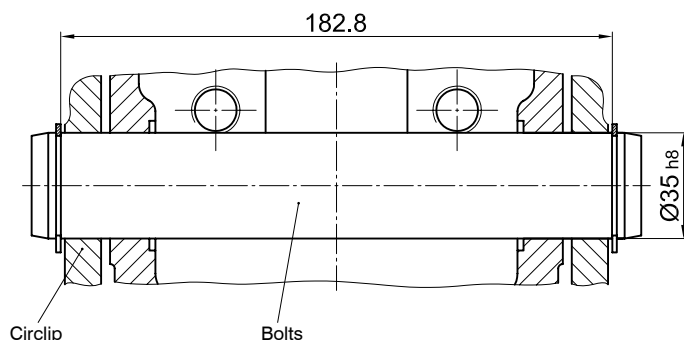

Lower support

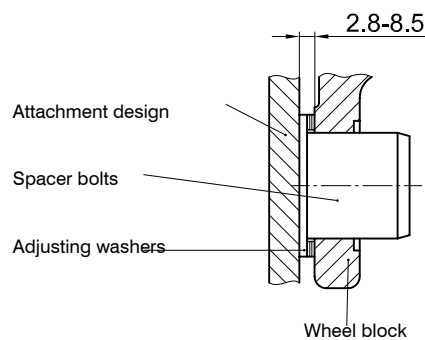

1) Dimension must be observed only with front mounting parts

Wheel block RB 250

Connection options

Pin attachment BA 250.2

Adjustable pin attachment for installation in hollow profiles, floating levers, etc.

Pin connection with option to align using adjustable hexagon screws. The alignment is done in assembled and relieved mode.

1 Set BA 250.2 comprising of:

- 2 Bolts Ø35 h8
- 4 Circlipse 35×1,5 DIN 471
- 4 Flanged bushings with internal thread (bonded)
- 4 Locking screws M16×50 (coated)

Pin connections are available in special design according to the customer drawing.

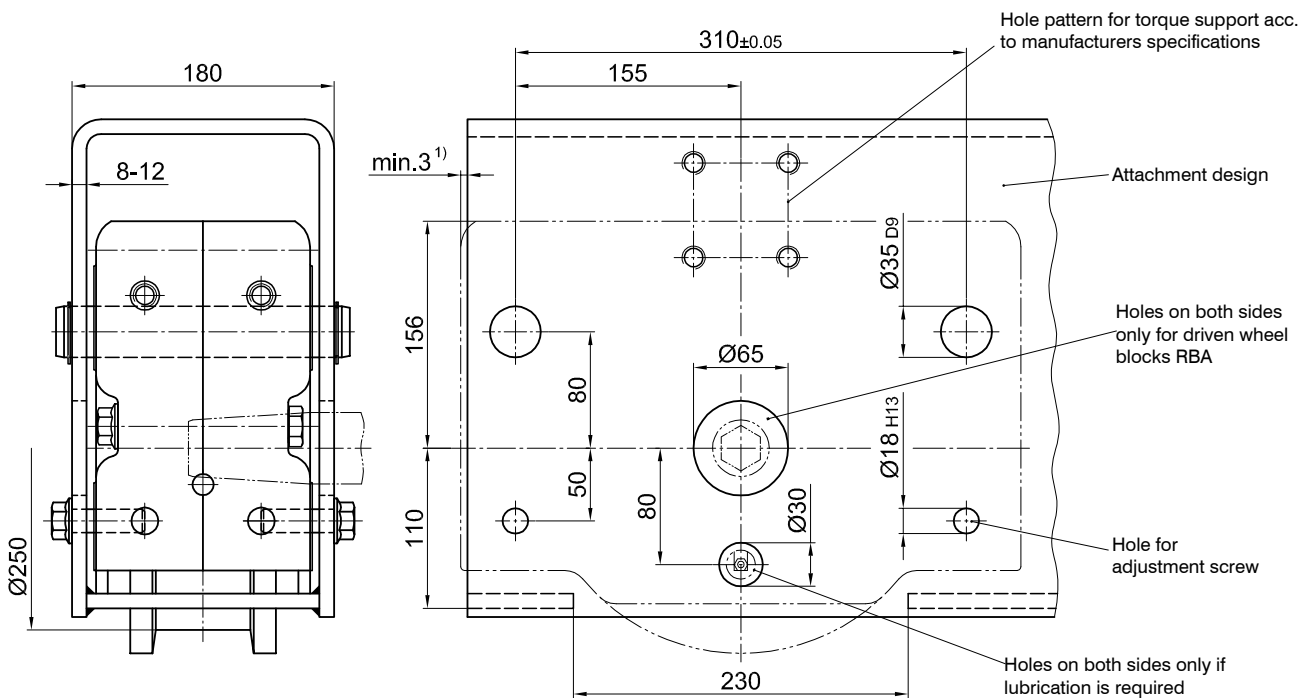

Upper suspension mounting

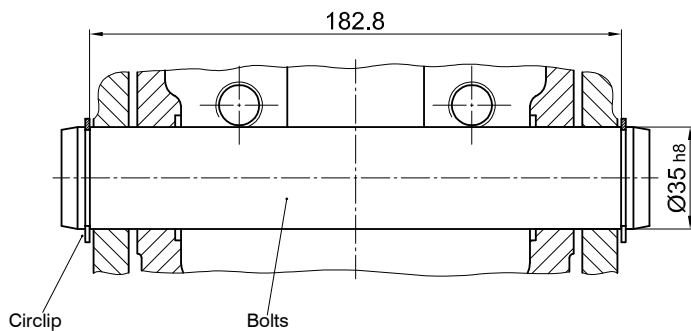

Lower support

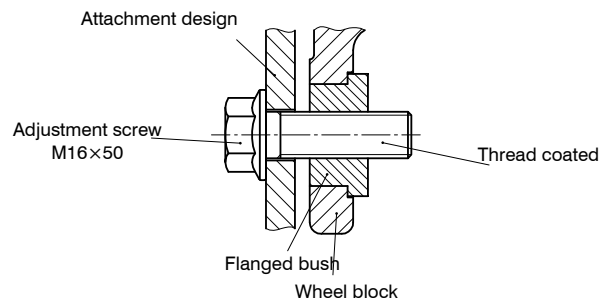

1) Dimension must be observed only with front mounting parts

Wheel block RB 250

Connection options

Pin attachment BA 250.3

Pin connection adjustable by grub screws for installation in hollow profiles, swingarms, etc.

Pin connection with alignment possibility by adjustable grub screws. The alignment is done in assembled and relieved mode.

1 Set BA 250.3 comprising of:

- 2 Bolts Ø35 h8
- 4 Circlipse 35×1,5 DIN 471
- 4 Grub screws with hexagon socket M 16×45-45H DIN EN ISO 4026 (DIN 913)
- 4 Safety nuts M 16-10

Pin connections are available in special design according to the customer drawing.

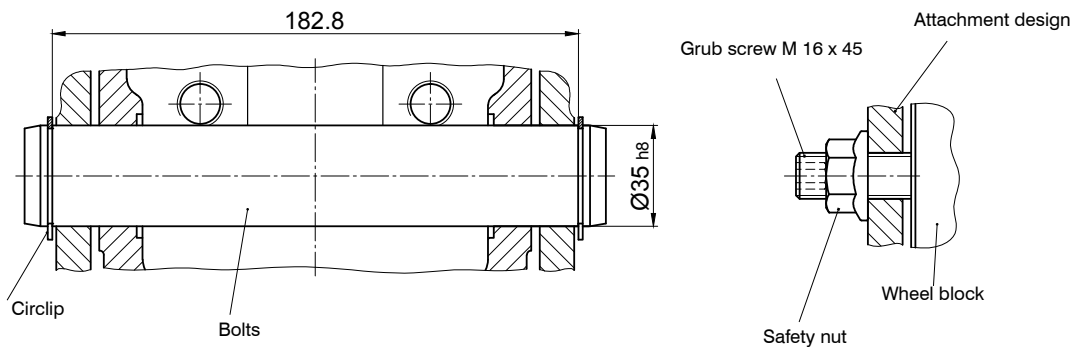
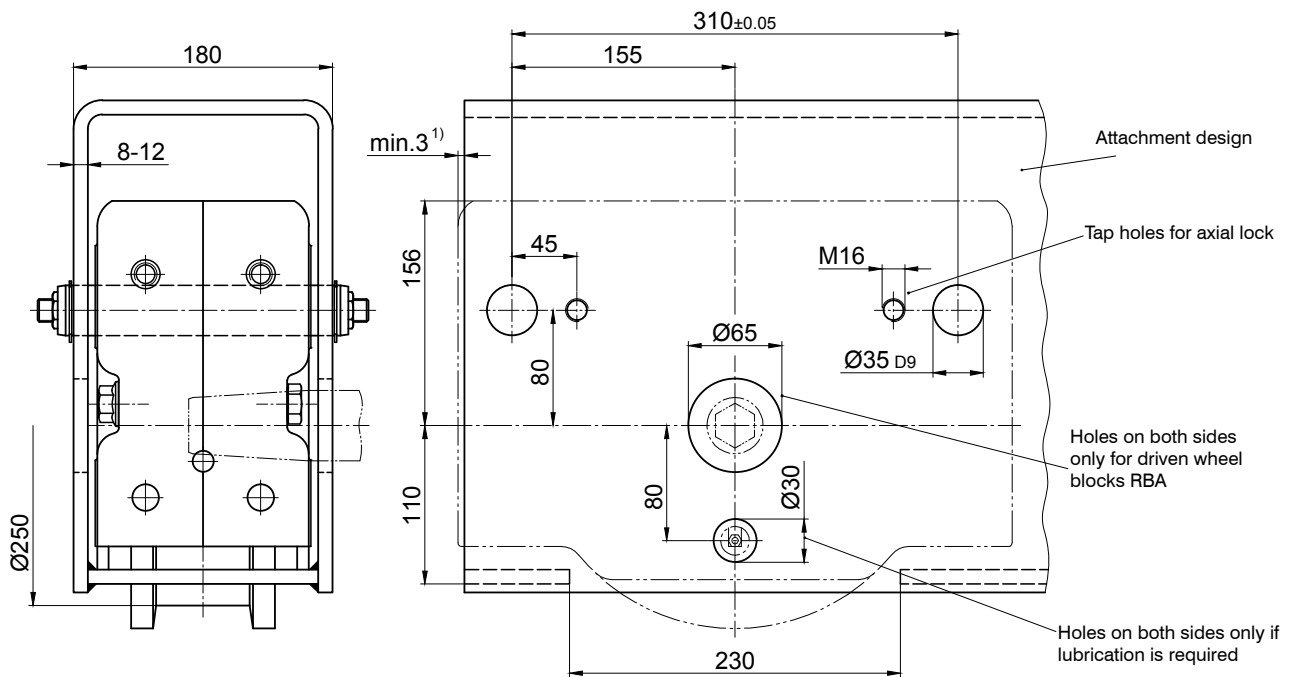

1) Dimension must be observed only with front mounting parts

Wheel block RB 250

Connection options

Side connection WA 250

Lateral connection option for low construction designs

- 1 Set WAA 250 (Side connection on the drive side)
- 1 Set WAN 250 (Side connection on the non-driven side)
- 1 Set WA 250 (Side connection on non-driven wheel block RBN) comprising of:

- 4 Flanged bushings $\varnothing 35$ (bonded)
- 4 Locking screws M16 \times 75 – 10.9
- 4 Safety nuts M16 – 10 DIN EN ISO 7042 (DIN 980)
- 4 Discs 17 / 45 \times 8

Attachment variant 1:

Attachment design is accessible from both sides

Trough-hole $\varnothing 35$ H12

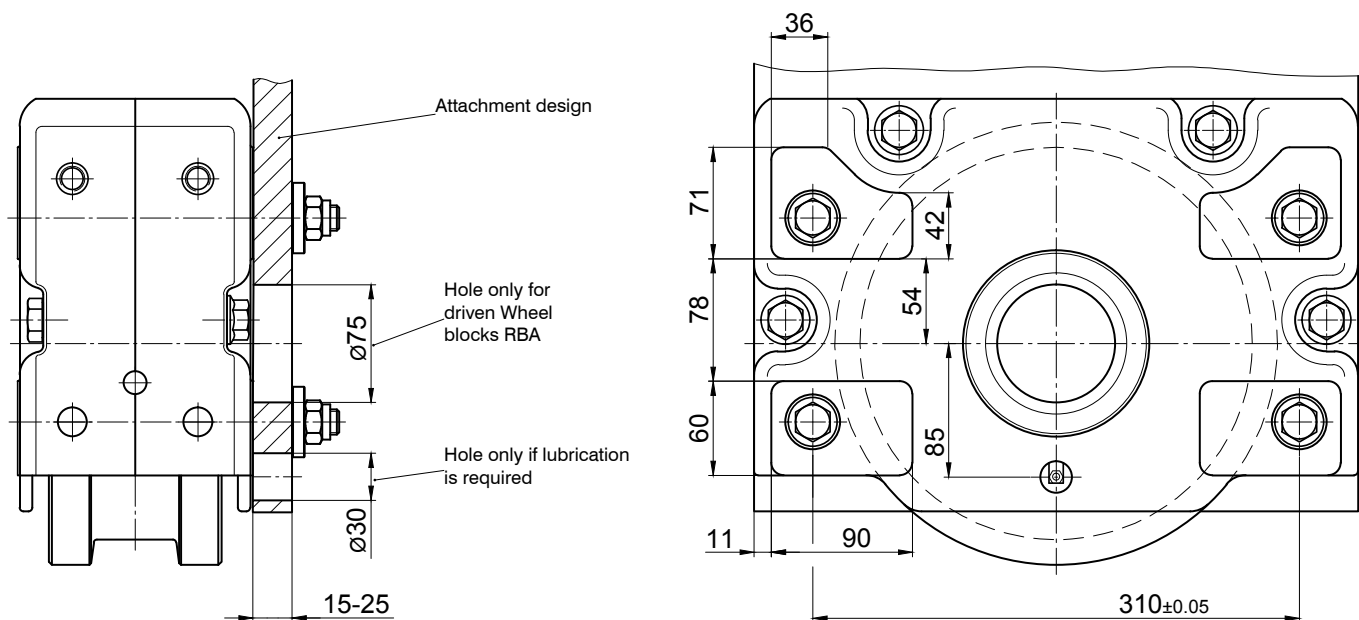

Sectional view

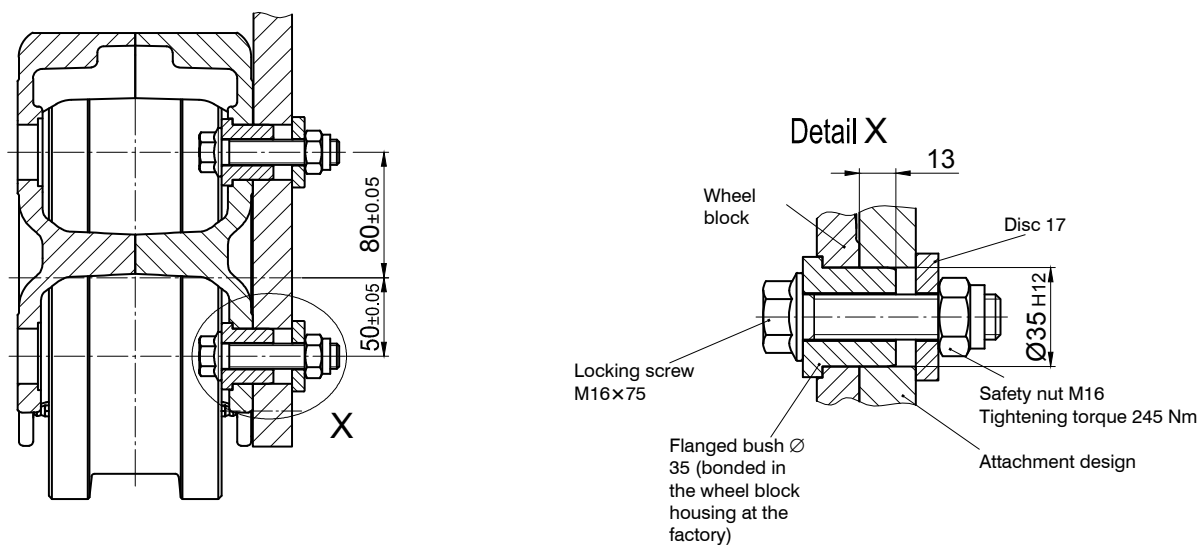

Wheel block RB 250

Connection options

Side connection WA 250

Lateral connection option for low construction designs

Attachment variant 2:

Attachment design (e.g. hollow profile) is not accessible from the inside

Blind hole $\varnothing 35$ H12 \times 15 deep with thread M16

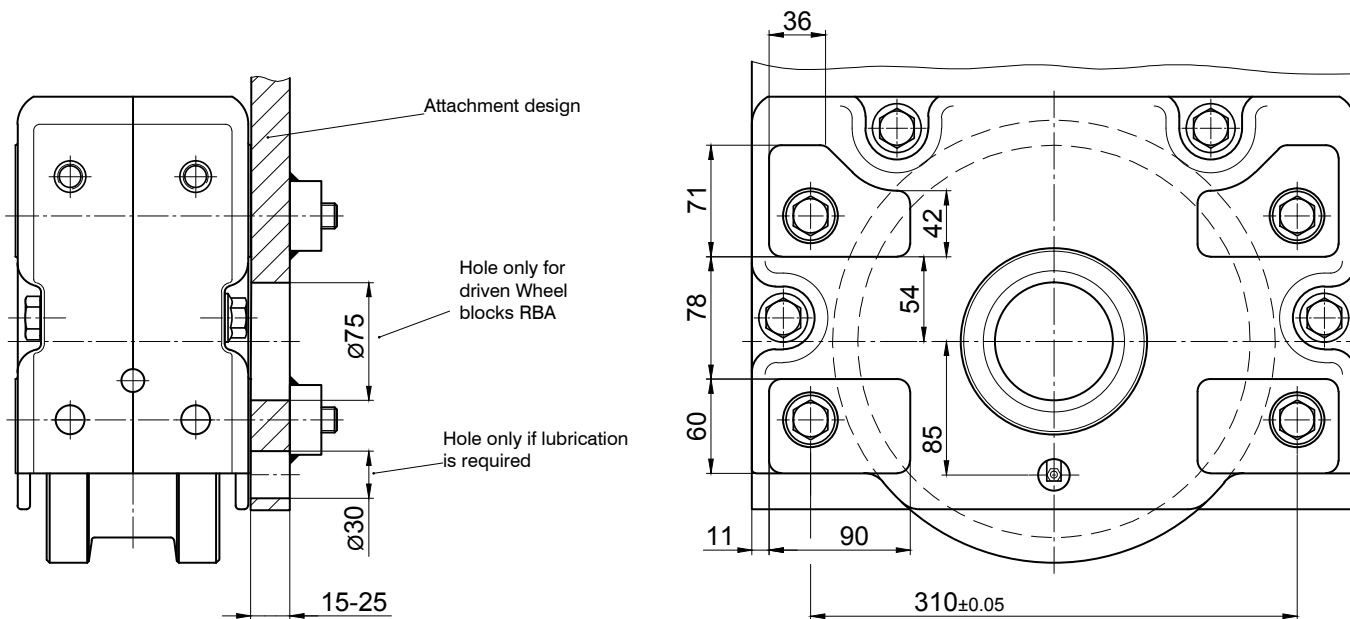

Sectional view

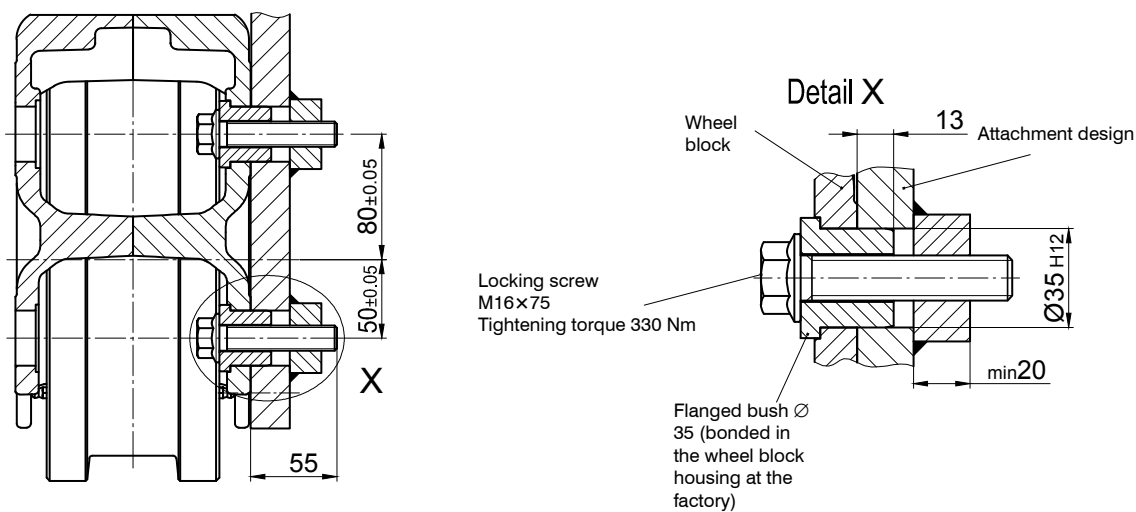

Wheel block RB 250

Drive shafts suitable for slip-on gear mechanisms from other manufacturers on request.

Single drive unit

Drive shaft suitable for slip-on gear mechanism with splined-shaft profile in accordance with DIN 5480

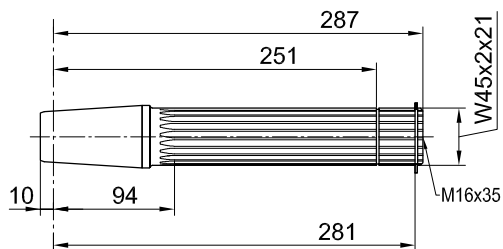
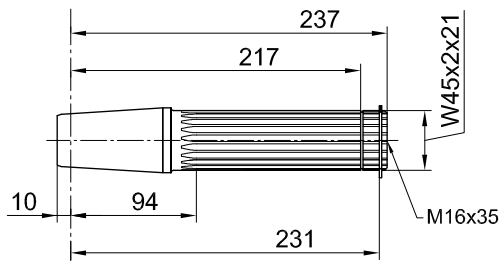
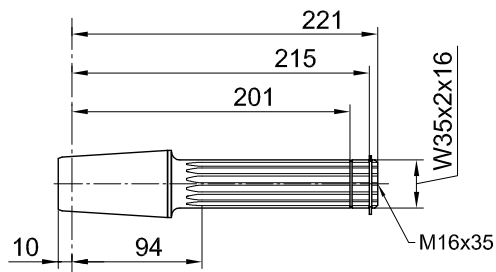

Slip-on gear mechanism		
Model	Manufacturer	Splined-shaft profile in acc. with DIN 5480
AF 05	DEMAG	W35 x 2 x 16
AUK 30		

AF 06	DEMAG	W45 x 2 x 21
AUK 40		

AF 08	DEMAG	W45 x 2 x 21
AUK 40		

Wheel block RB 250

Drive shafts suitable for slip-on gear mechanisms from other manufacturers on request.

Single drive unit

Drive shaft suitable for slip-on gear mechanism with splined-shaft profile in accordance with DIN 5480

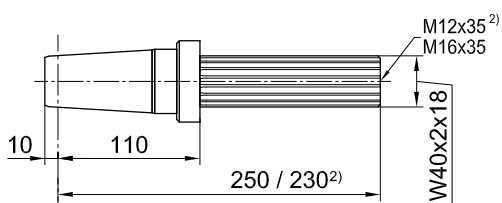
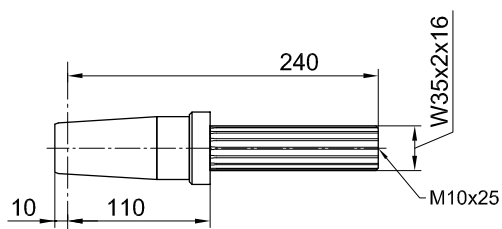
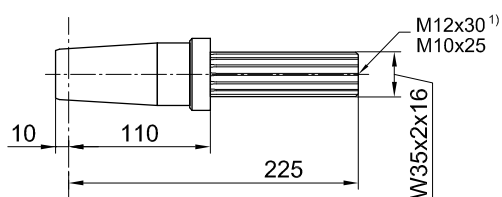

Slip-on gear mechanism		
Model	Manufacturer	Splined-shaft profile in acc. with DIN 5480
FV 47 / KV 47	SEW	W35 x 2 x 16
SK 2282 EA ¹⁾	NORD	
SPZT / SKZT 26..	PREMIUM STEPHAN	

FV 57 / KV 57	SEW	W35 x 2 x 16
---------------	-----	--------------

F.A.T 48B ²⁾	SIEMENS (FLENDER)	W40 x 2 x 18
KA.T 48 ²⁾		
CA.T 48 ²⁾		
SK 3282 EA	NORD	
SK 9023.1A.EA		

Wheel block RB 250

Drive shafts suitable for slip-on gear mechanisms from other manufacturers on request.

Single drive unit

Drive shaft suitable for slip-on gear mechanism with splined-shaft profile in accordance with DIN 5480

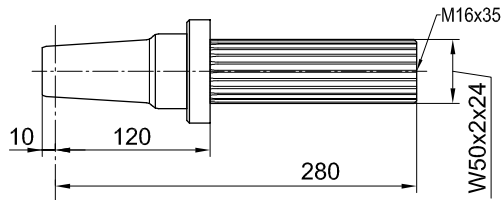
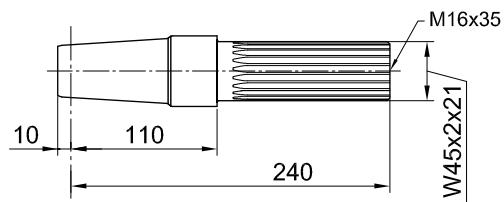

Slip-on gear mechanism		
Model	Manufacturer	Splined-shaft profile in acc. with DIN 5480
FV 67 / KV 67	SEW	W45 x 2 x 21
SPZT / SKZT 36..	PREMIUM STEPHAN	

FV 77 / KV 77	SEW	W50 x 2 x 24
SK 4282 EA	NORD	
SPZT / SKZT 46..	PREMIUM STEPHAN	

Wheel block RB 250

Drive shafts suitable for slip-on gear mechanisms from other manufacturers on request.

Single drive unit

Drive shaft suitable for slip-on gear mechanism with feather key connection in accordance with DIN 6885

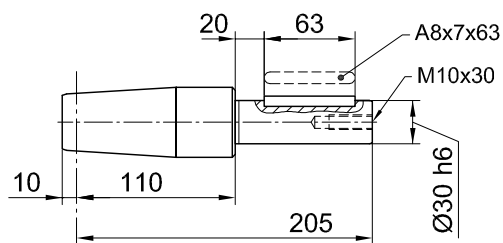

Slip-on gear mechanism		
Model	Manufacturer	Shaft journal
FA / KA 37 SA 47	SEW	Ø 30
FDA / FZA 38 B KA / CA 38	SIEMENS (FLENDER)	
O 32..H O 33..H K 33..H C 32..H	SIEMENS	
SK 0282 NBAB SK 1282 AB	NORD	
GFL 04..H GKS 04..H GSS 04..H	LENZE	
F 3..A	STÖBER	

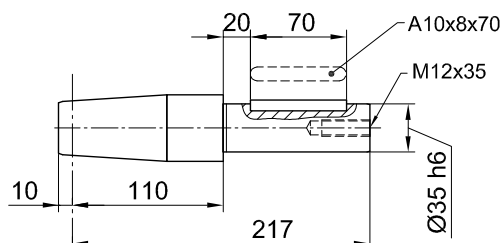

FA / KA 47 SA 57	SEW	Ø 35
SK 2282 AB	NORD	
FDA / FZA 48 B KA / CA 48	SIEMENS (FLENDER)	
O 42..G O 43..G K 43..H C 42..H	SIEMENS	
GFL 05..H GKS 05..H GSS 05..H	LENZE	
K1..A S2..A	STÖBER	
SPZH 26.. SKZH 26..	PREMIUM STEPHAN	

Wheel block RB 250

Drive shafts suitable for slip-on gear mechanisms from other manufacturers on request.

Single drive unit

Drive shaft suitable for slip-on gear mechanism with feather key connection in accordance with DIN 6885

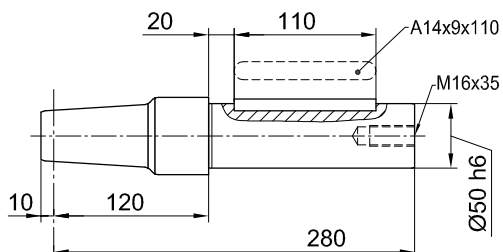
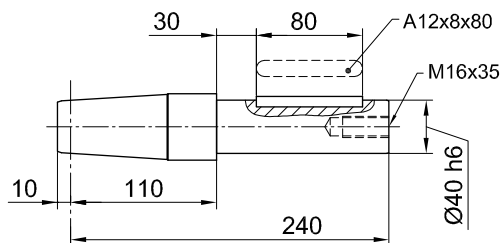

Slip-on gear mechanism		
Model	Manufacturer	Shaft journal

FA 57 / KA 57 FA 67 / KA 67 SA 67	SEW	Ø 40
SK 3282 AB	NORD	
FDA 68 B FZA 68 B KA 68 / CA 68	SIEMENS (FLENDER)	
O 62..G O 63..G K 63..G C 62..G	SIEMENS	
K4..A	STÖBER	
SPZH 36.. SKZH 36..	PREMIUM STEPHAN	

FA 77 KA 77 SA 77	SEW	Ø 50
SK 4282 AB	NORD	
FDA 88 B FZA 88 B KA 88 CA 88	SIEMENS (FLENDER)	
O 82..G O 83..G K 83..G C 82..G	SIEMENS	
GFL 07..H GKS 07..H GSS 07..H	LENZE	
K 5..A K 6..A	STÖBER	
SPZH 46.. SKZH 46..	PREMIUM STEPHAN	

Wheel block RB 250

Drive shafts suitable for slip-on gear mechanisms from other manufacturers on request.

Central drive unit

Both wheel blocks are driven with only one gear motor
(Splined-shaft profile, feather key connection and shrink disc attachment)

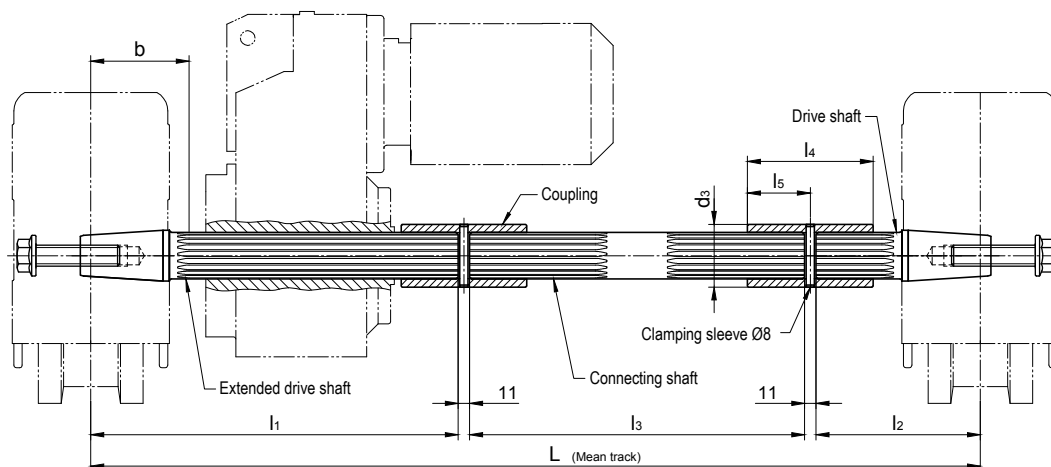

Model	Manufacturer	Splined-shaft-profile DIN 5480	L	l1	l2	l3	Centre RB to gearing b	l4	l5	d3	Clamping sleeve DIN 1481
AF 05 AUK 30/ WUK 30	DEMAG	W35 x 2 x 16	For ordering, please provide	350	225	Dimension L minus 597	95	100	50	50	8 x 50
FV 47 / KV 47 FV 57 / KV 57	SEW										
SK 2282 EA	NORD										
SPZT 26.. SKZT 26..	PREMIUM STEPHAN	W40 x 2 x 18		350	148	Dimension L minus 520	110	100	50	55	8 x 55
F.A.T 48 B KA.T 48 CA.T 48	SIEMENS (FLENDER)										
SK 3282 EA SK 9023.1A.EA	NORD										
AF 06 / AF 08 AUK 40	DEMAG	W45 x 2 x 21		351	157	Dimension L minus 530	94	120	60	60	8 x 60
FV 67 KV 67	SEW										
SPZT 36.. SKZT 36..	PREMIUM STEPHAN										
AF 08 AUK 50	DEMAG	W50 x 2 x 24		400	158	Dimension L minus 580	95	120	60	65	8 x 65
FV 77 KV 77	SEW										
SK 4282 EA SK 9033.1A.EA	NORD										
F.A.T 68 B KA.T 68 CA.T 68	SIEMENS (FLENDER)										
SPZT 46.. SKZT 46..	PREMIUM STEPHAN										

Wheel block RB 250

Drive shafts suitable for slip-on gear mechanisms from other manufacturers on request.

Central drive unit

Both wheel blocks are driven with only one gear motor
(Splined-shaft profile, feather key connection and shrink disc attachment)

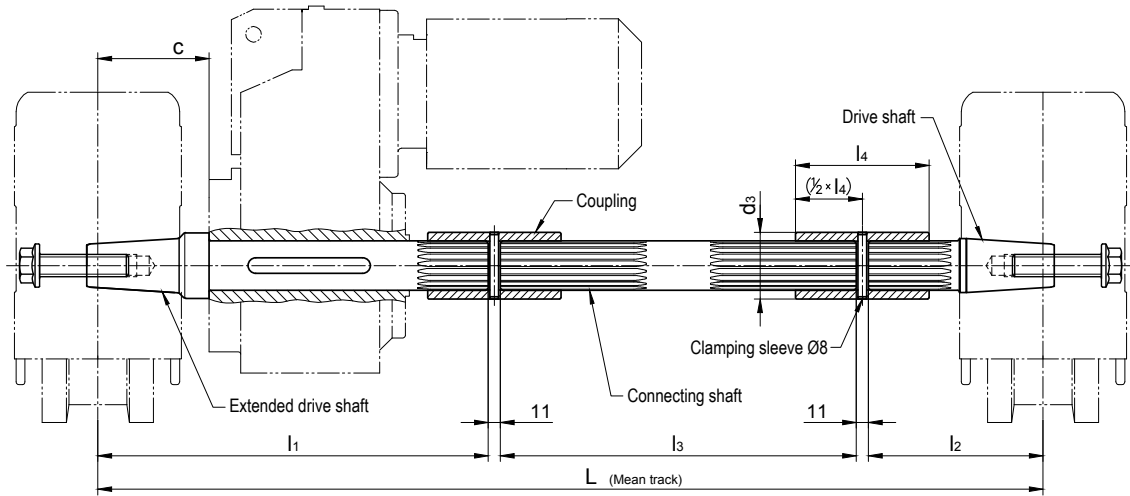

For gearboxes with hollow shaft and feather key connection in acc. with DIN 6885

Suitable for gearboxes with hollow shaft		L	I1	I2	I3	c Getriebe- anschlag	Feather key DIN 6885	Coupling Internal gearing/ d3 x l4
Inner- \varnothing	Length							
$\varnothing 30$	≤ 140	For ordering, please provide	290	195	Dimension L minus 507	110	A 8 x 7 x 70	N30 x 1,25 x 22 $\varnothing 40 \times 80$
$\varnothing 35$	≤ 150		320	225	Dimension L minus 567	110	A 10 x 8 x 70	N35 x 2 x 16 $\varnothing 50 \times 100$
$\varnothing 40$	≤ 180		350	148	Dimension L minus 520	110	A 12 x 8 x 100	N40 x 2 x 18 $\varnothing 55 \times 100$
$\varnothing 50$	≤ 210		400	158	Dimension L minus 580	120	A 14 x 9 x 110	N50 x 2 x 24 $\varnothing 60 \times 120$

Suitable for gearboxes of the following manufacturers:

Siemens Motox (Flender), Bauer (Danfoss), KEB, Lenze, Nord, PREMIUM STEPHAN, SEW, Siemens, Stöber, Demag

Et.al. suitable type designations, refer to the single drive unit.

Drive shafts without gearbox stop and with adapted distance (c) on request.

Wheel block RB 250

Horizontal roller guide for wheels of $\varnothing 250$ (Form 1-5)

Horizontal roller guide with adjustable guide rollers made of 42CrMo4+QT.

The installation of a cellular plastic buffer (page 144) is possible without spacer discs. Parallel operating wheel blocks without horizontal roller guide can be installed with spacer discs for length compensation (see fig.).

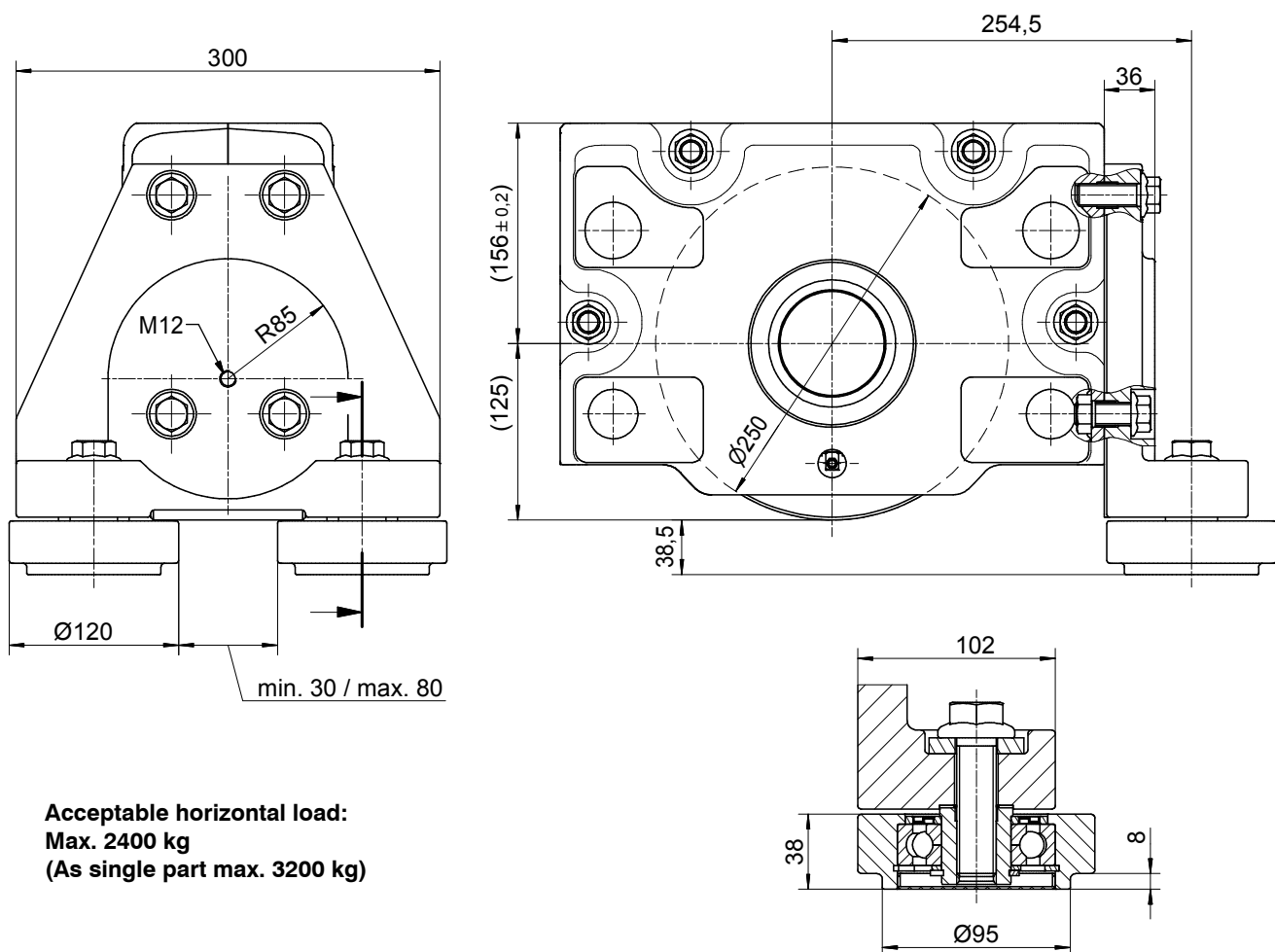
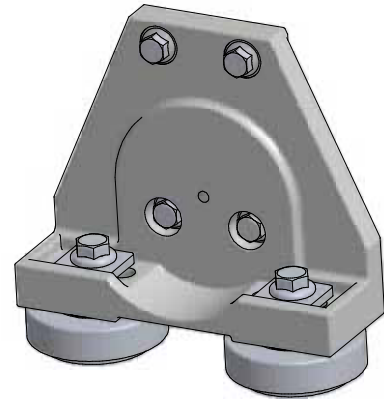

Acceptable horizontal load:
Max. 2400 kg
(As single part max. 3200 kg)

All necessary fastening elements are included in the scope of delivery.

Horizontal roller guide for other rail profiles are available on request.

Wheel block RB 250

Horizontal roller guide
 for wheels of $\varnothing 290$ and $\varnothing 285$
 with coating made of vulkollan or PA12G

Horizontal roller guide with adjustable guide rollers made of PA12G.

The installation of a cellular plastic buffer is possible by using an additional spacer discs.

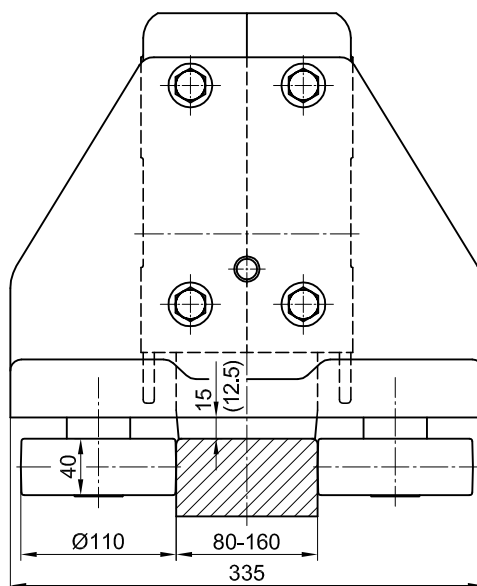
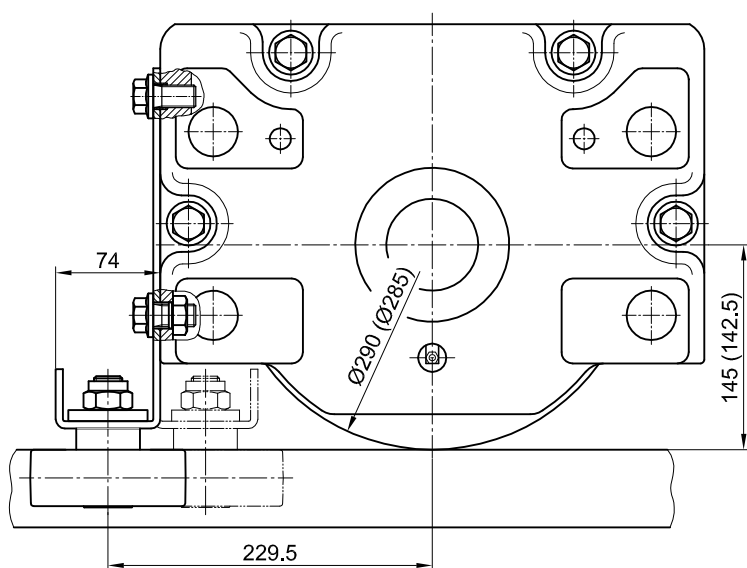
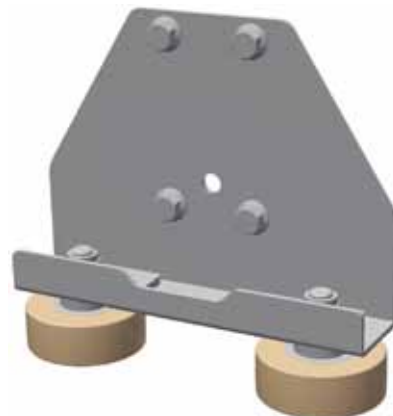

Acceptable continuous load: 700 kg
 Maximum short-term load: 1100 kg

Magnified detail drawing of the guide roller

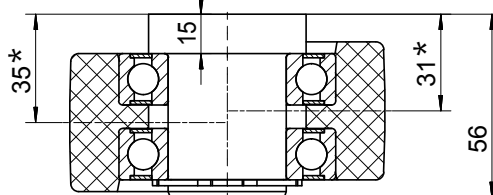

By turning the unsymmetrical guide roller, two clearances* can be adjusted.

All necessary fastening elements are included in the scope of delivery.

Horizontal roller guide for other rail profiles are available on request.