

Wheel block

RB 400

Wheel block RB 400

Primary dimensions

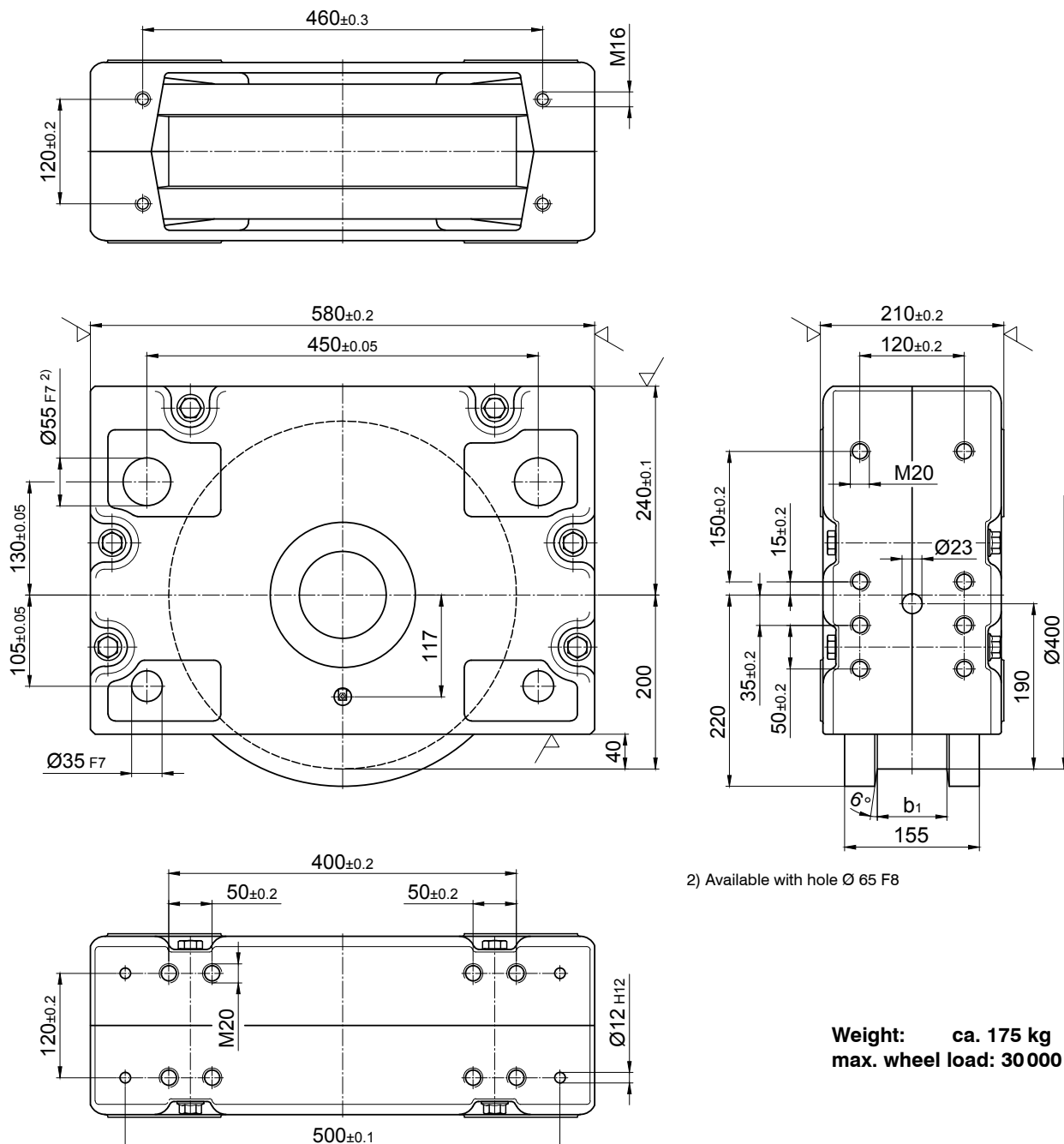

2) Available with hole $\varnothing 65$ F8

Weight: ca. 175 kg
max. wheel load: 30 000 kg

Ordering examples

RBA 400×80

Wheel block 400, driven, with internal taper, with two-sided wheel flange, design Form 1, running tread 80 mm

RBN 400×80

Wheel block 400, non-driven, without internal taper, with two-sided wheel flange, design Form 1, running tread 80 mm

RBA 400×110

Wheel block 400, driven, with internal taper, with one-sided wheel flange design Form 2, running tread 110 mm

RBA 400×155

Wheel block 400, driven, with internal taper, without wheel flanges, design Form 4

Design RBA and RBN refer to Page 5

Wheel block RB 400

Standard models

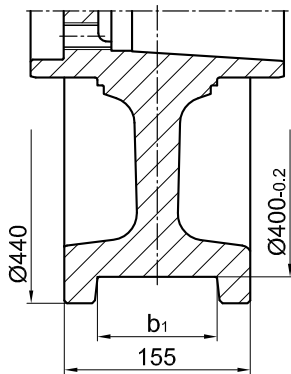

Form 1
two-sided wheel flange

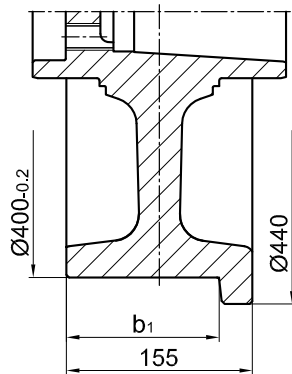

Form 2¹⁾
one-sided wheel flange
on the drive side

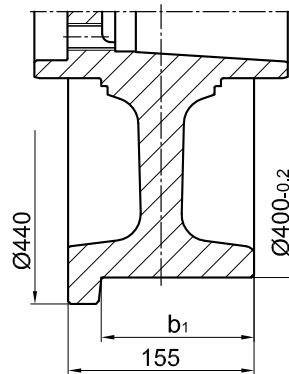

Form 3¹⁾
one-sided wheel flange
opposite to the drive side

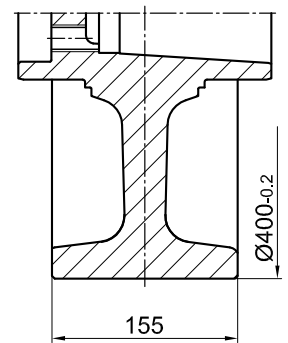

Form 4
no wheel flanges with
cylindrical running surface

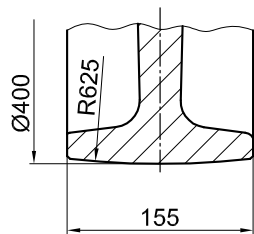

Form 5
no wheel flanges with
spherical running surface

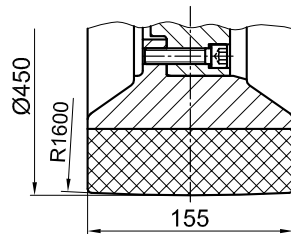

Form 6
with coating
of PA 12 G

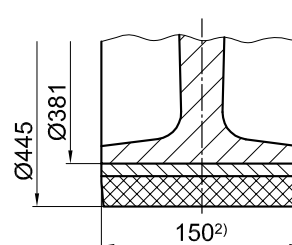

Form 8
with binding
of Vulkollan

Special models

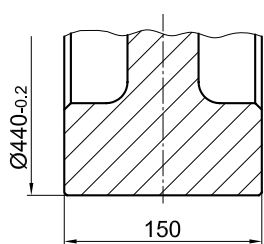

Form 9
no wheel flanges, wide
with cylindrical running surface

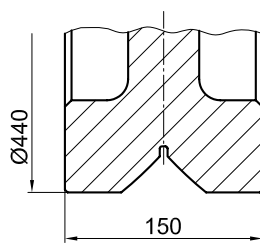

Form 10
with prismatic guide

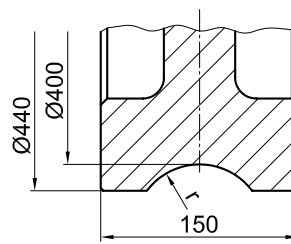

Form 11
with concave groove
 $r = 1,1 \times \text{track radius}$
(recommended)

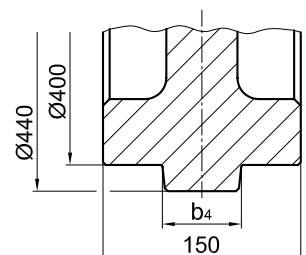

Form 12
with middle wheel flange

Form 1			Form 2 and 3	
Running tread b_1 or two-sided wheel flange			Running tread b_1 or one-sided wheel flange	
minimal	maximal	Standard	minimal	maximal
60	120	80	110	137,5

All models are available with wheel width up to 160 mm

1) Forms 2 and 3 are identical for the non-driven Wheel block RBN

2) Available as special design with binding width 160 mm

Wheel block RB 400

Connection options

Top connection KA 400.1

Precisely fitted direct attachment as bolted connection (welded construction, roll section, etc.)

Top connection using locking screws for installation in accurately drilled connecting constructions. No adjustment of the wheel block is required.

1 Set KA 400.1 comprising of:

- 8 Hexagon screw with thread locking M20×55 – 10.9
DIN EN ISO 4017 (DIN 933)
- 8 Discs Ø 37 / 20,5×5
- 4 Locking pins 12×30 DIN EN ISO 8752 (DIN 1481)

Mounting parts for larger sheet thicknesses and/or adjustable direct connection are available on request.

For the directional version refer to the pattern of drilling KA 400.2 (Page 126).

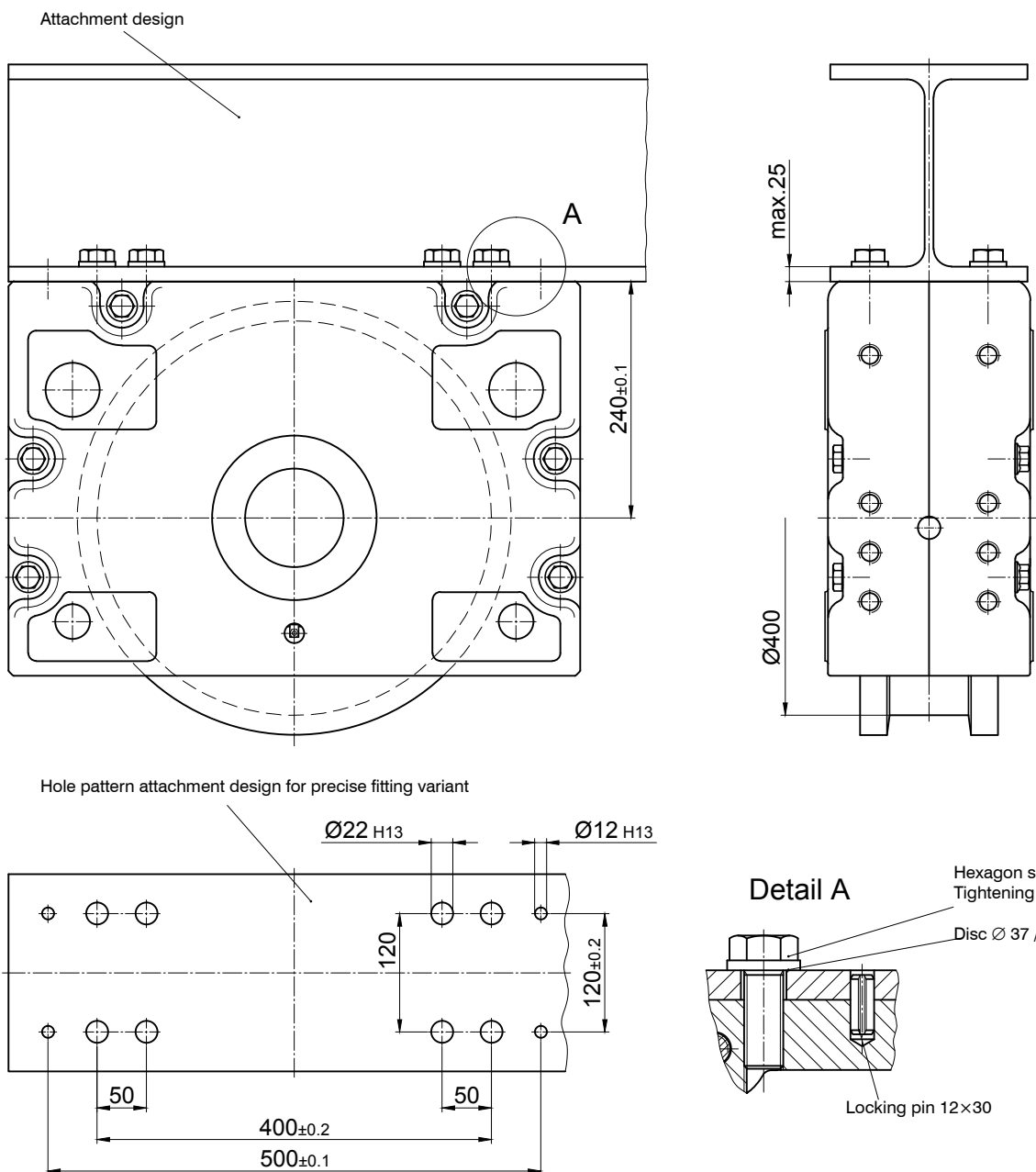

Wheel block RB 400

Connection options

Top connection KA 400.2

Adjustable direkt attachment as bolted connection (welded construction, roll section, etc.)

Top connection using locking pins for installation in attachment design with precisely or larger drilled attachment holes
For larger drilled attachment holes, the wheel block must be aligned. Subsequently, the wheel block is attached by bolts and should be drilled with the locking pins 12×30 supplied. However, this should not be done in the area of the attachment bolts or the existing adjusting pin hole [1]). Alignment is not required for precisely drilled attachment holes.

1 Set KA 400.2 comprising of:

- 8 Grub screws M20×120 - 10.9 ZT
- 8 Safety nuts M20-10 DIN EN ISO 7042 (DIN 980)
- 8 Discs 21 DIN 6340
- 4 Locking pins 12×30 DIN EN ISO 8752 (DIN 1481)

Longer locking pins are available for thicker plates.

Attachment design

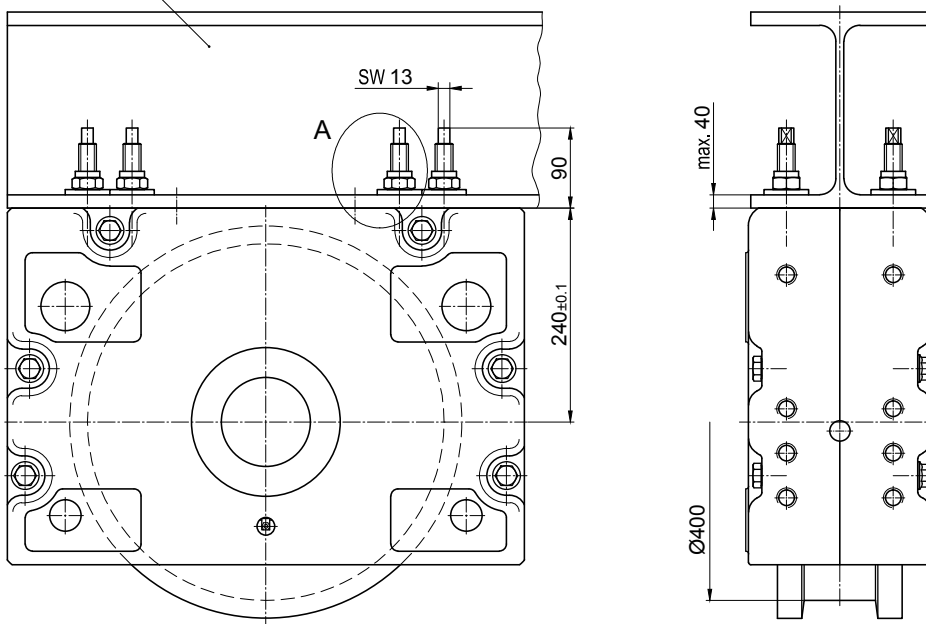

Hole pattern for the attachment design for adjustable variant.

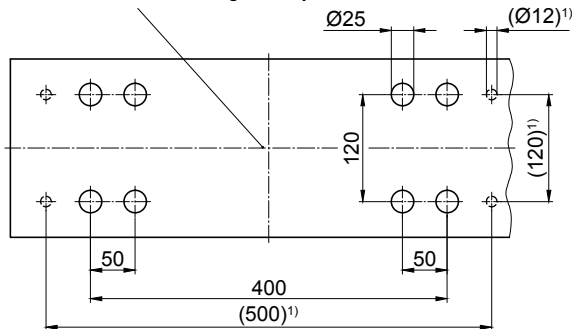

Detail A

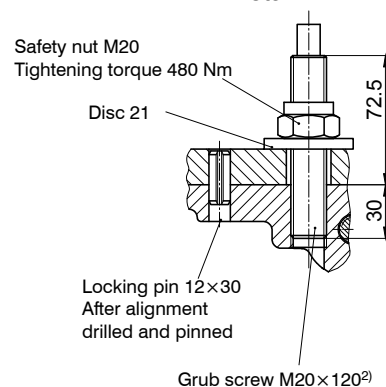

1) Pinning is not permitted in this area !

2) Can be factory-glued in the wheel block housing on request

Wheel block RB 400

Connection options

Pin attachment BA 400.1

Pin attachment is adapted to the installation in hollow profiles, floating levers, etc. by means of adjusting washers.

Pin attachment with alignment option using adjusting washers. Alignment option by replacing the adjusting washers only in dismantled condition.

1 Set BA 400.1 comprising of:

- 2 Bolts $\text{Ø}55\text{h}8$
- 4 Circlipse 55×3 DIN 471
- 4 Supporting discs S 55×68 DIN 988
- 4 Spacer bolts
- 100 Adjusting washers 35×45×0,5 DIN 988

Pin connections are available in special design according to the customer drawing.

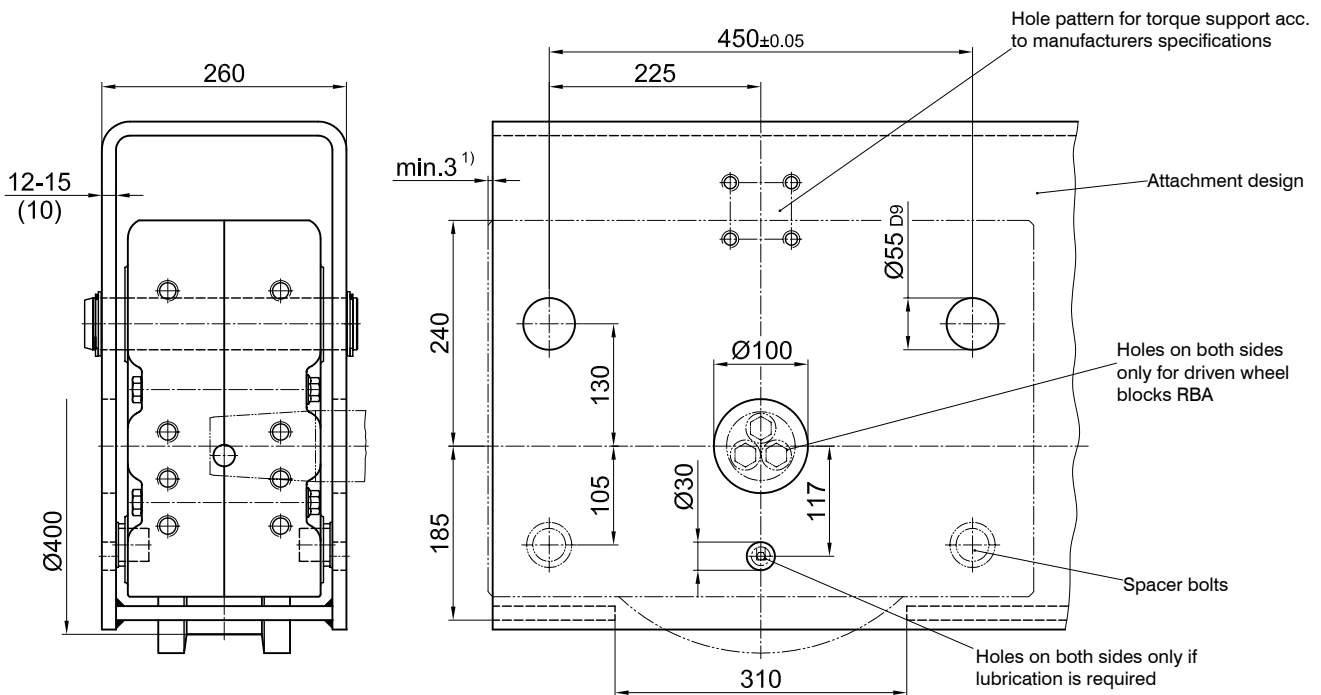

Upper suspension mounting

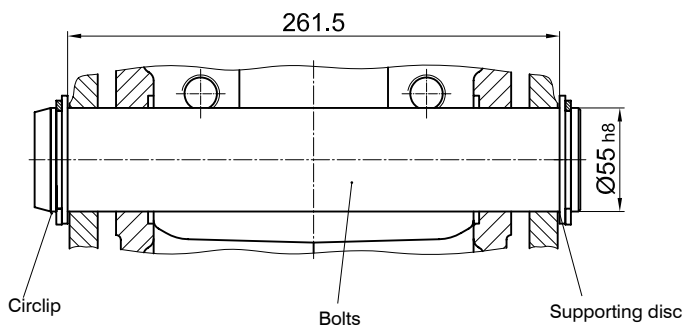

Lower support

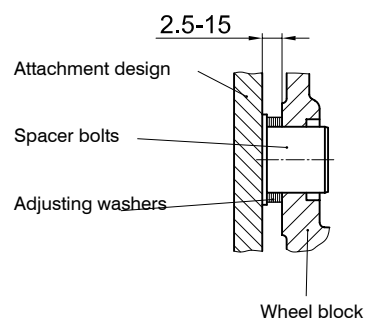

1) Dimension must be observed only with front mounting parts

Wheel block RB 400

Connection options

Pin attachment BA 400.2

Adjustable pin attachment for installation in hollow profiles, floating levers, etc.

Pin connection with option to align using adjustable hexagon screws. The alignment is done in assembled and relieved mode.

1 Set BA 400.2 comprising of:

- 2 Bolts $\text{Ø}55$ h8
- 4 Circlipse 55×3, DIN 471
- 4 Supporting discs S 55×68 DIN 988
- 4 Flange bushings with internal thread (bonded)
- 4 Locking screws M16×70 (coated)

Pin connections are available in special design according to the customer drawing.

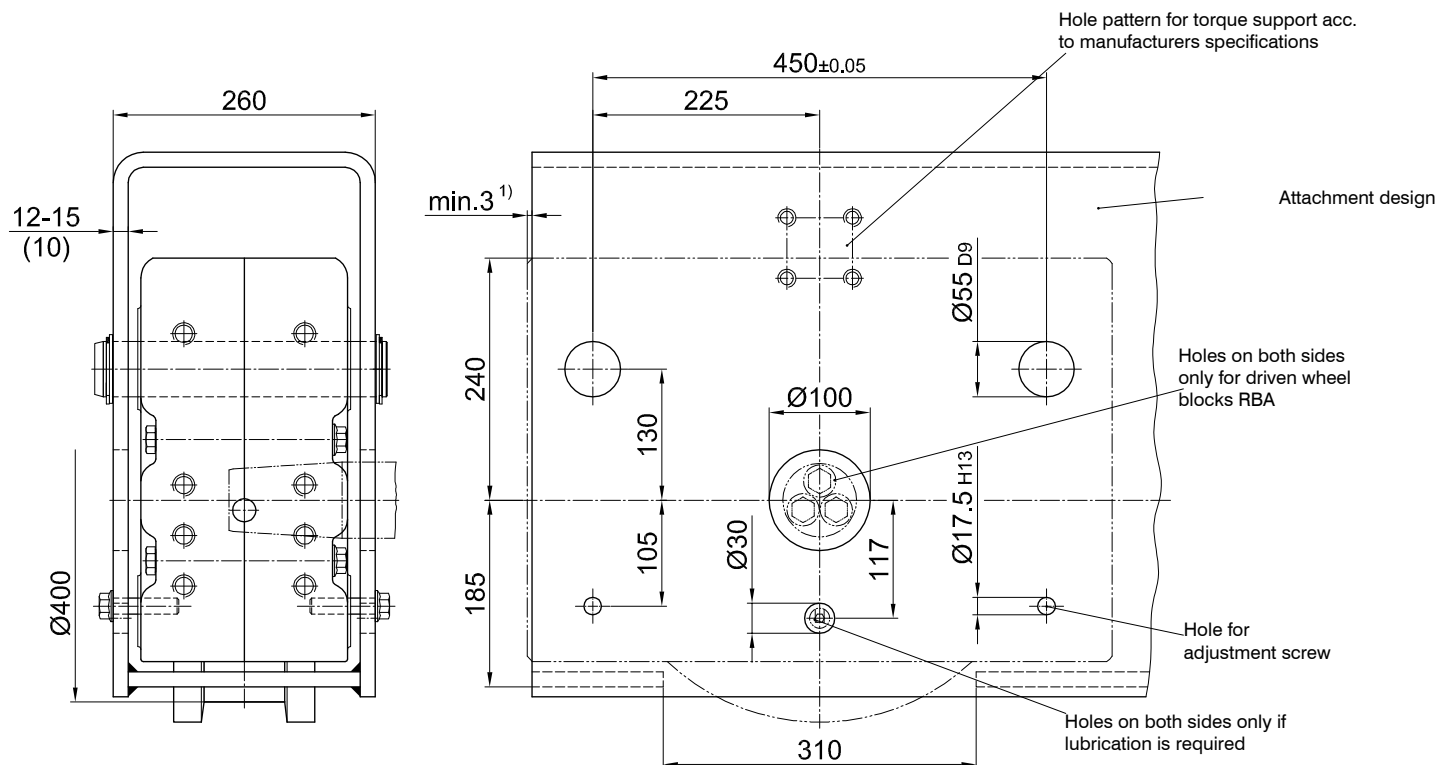

Upper suspension mounting

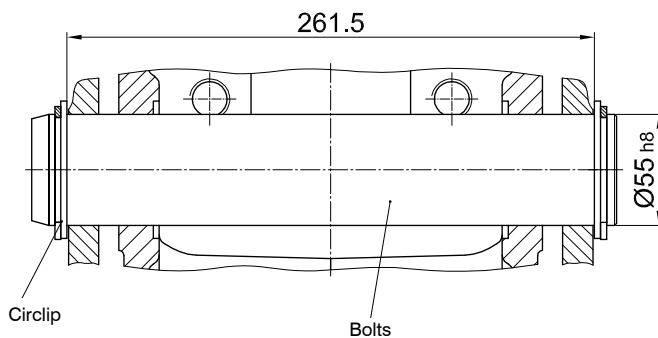

Lower support

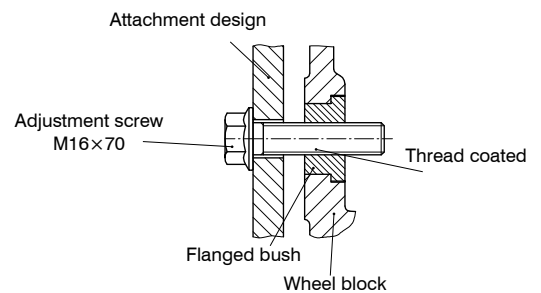

1) Dimension must be observed only with front mounting parts

Wheel block RB 400

Connection options

Pin attachment BA 400.3

Pin connection adjustable by grub screws for installation in hollow profiles, swingarms, etc.

Pin connection with alignment possibility by adjustable grub screws. The alignment is done in assembled and relieved mode.

1 Set BA 400.3 comprising of:

- 2 Bolts Ø55 h8
- 4 Circlip 55×3, DIN 471
- 4 Supporting discs S 55×68 DIN 988
- 4 Grub screws with hexagon socket M 20 x 60 - 45H DIN 913
- 4 Safety nuts M20

Pin connections are available in special design according to the customer drawing.

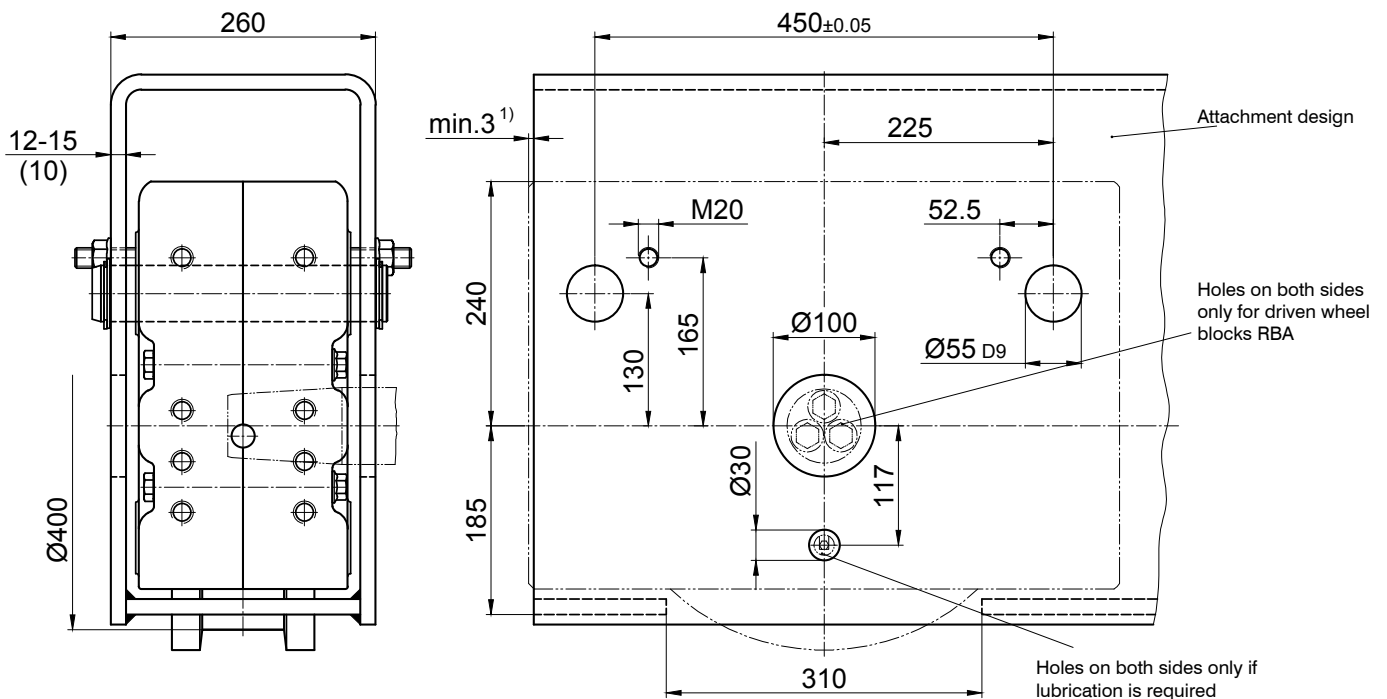

Upper suspension mounting

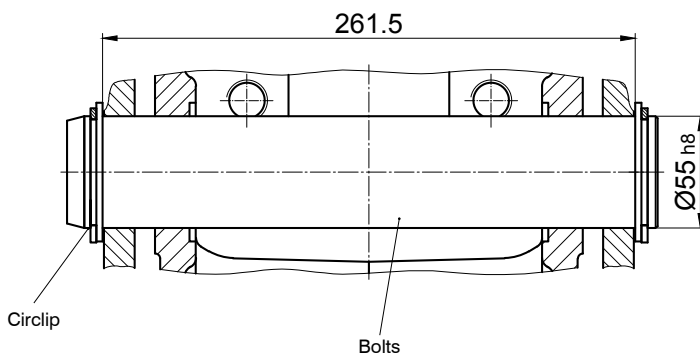

Lower support

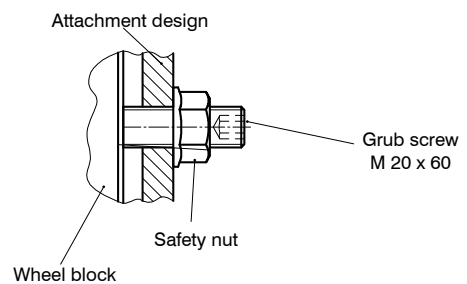

1) Dimension must be observed only with front mounting parts

Wheel block RB 400

Connection options

Side connection WA 400

Lateral connection option for low construction designs

- 1 Set WAA 400 (Side connection on the drive side)
- 1 Set WAN 400 (Side connection on the non-driven side)
- 1 Set WA 400 (Side connection on non-driven wheel block RBN) comprising of:

- 2 Flanged bushings $\varnothing 55$
- 2 Hexagon screwn M24 \times 100 – 10.9 DIN EN ISO 4014 (DIN 931)
- 2 Safety nuts M24 – 10 DIN EN ISO 7042 (DIN 980)
- 2 Discs 25 / 72 \times 13
- 2 Flanged bushings $\varnothing 35$
- 2 Hexagon screwn M16 \times 80 – 10.9 DIN EN ISO 4014 (DIN 931)
- 2 Safety nuts M16 – 10 DIN EN ISO 7042 (DIN 980)
- 2 Discs 17 / 45 \times 8

Attachment variant 1:

Attachment design is accessible from both sides

Trough-hole $\varnothing 55$ H12

Trough-hole $\varnothing 35$ H12

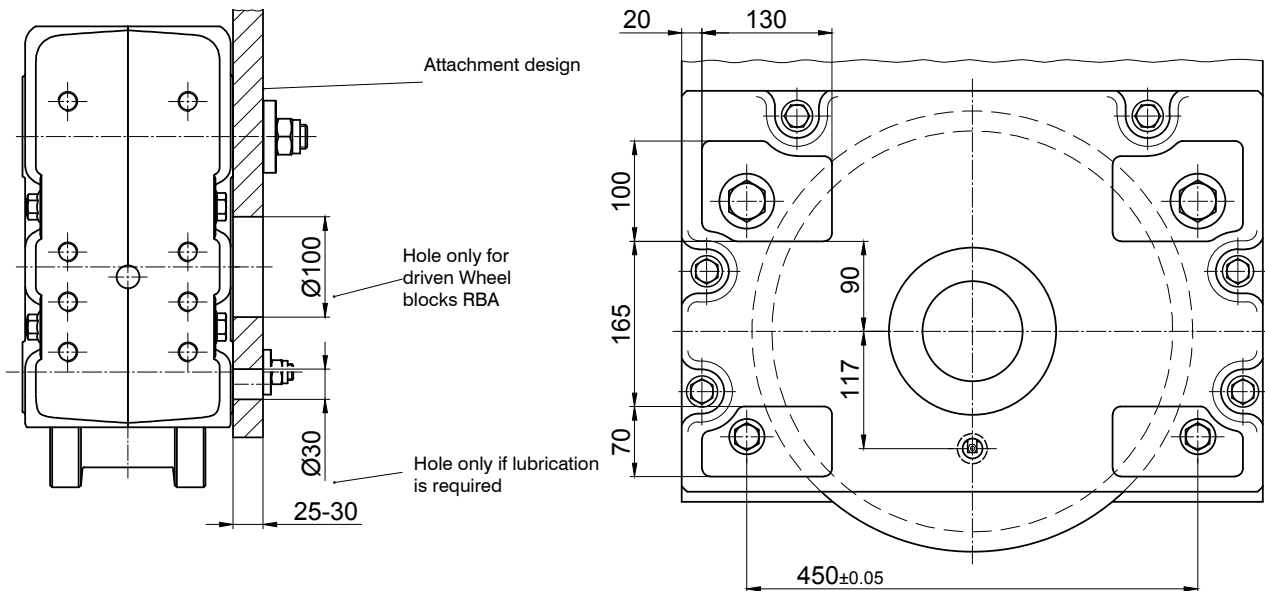

Sectional view

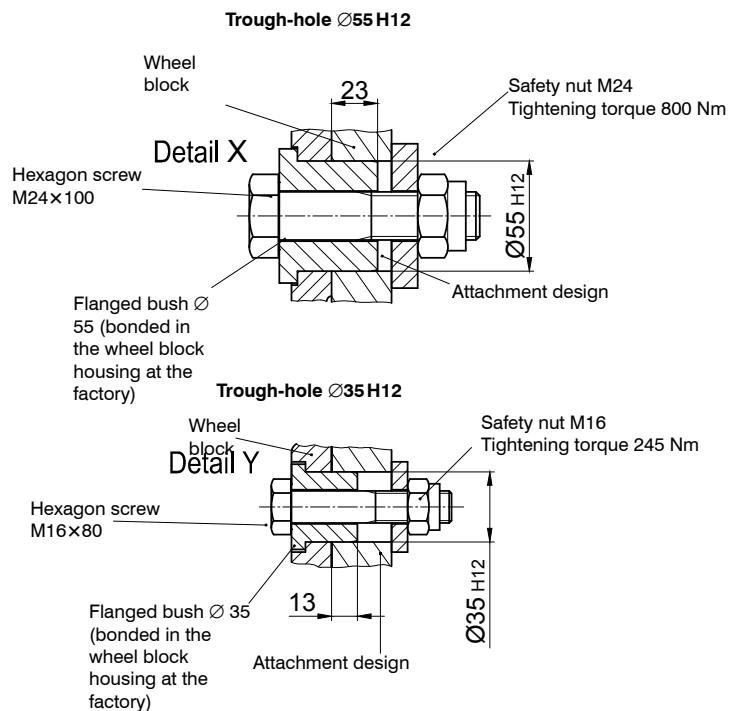
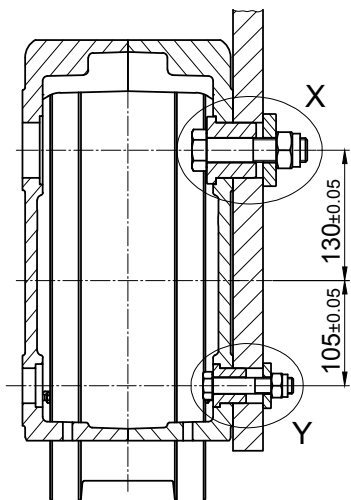

Wheel block RB 400

Connection options

Side connection WA 400

Lateral connection option for low construction designs

Attachment variant 2:

Attachment design (e.g. hollow profile) is not accessible from the inside

Blind hole $\varnothing 55$ H12 \times 30 deep with thread M24 and

Blind hole $\varnothing 35$ H12 \times 20 deep with thread M16

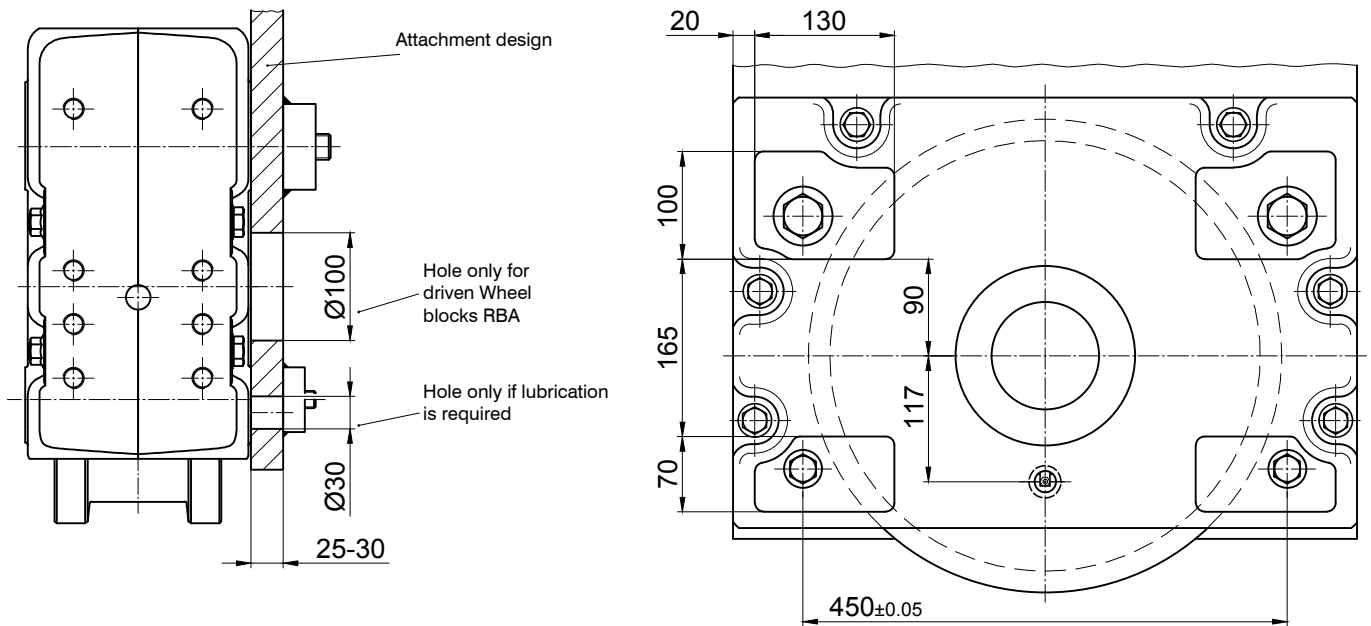

Sectional view

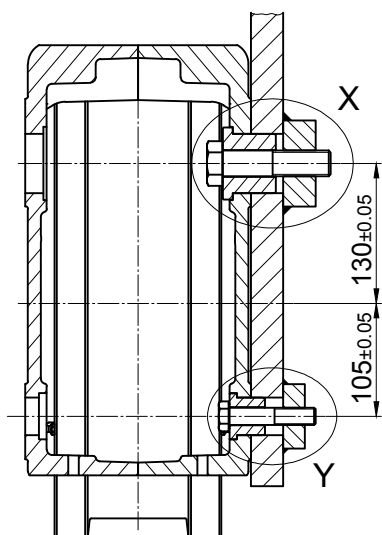

Blind hole $\varnothing 55$ H12 \times 30 deep with thread M 24

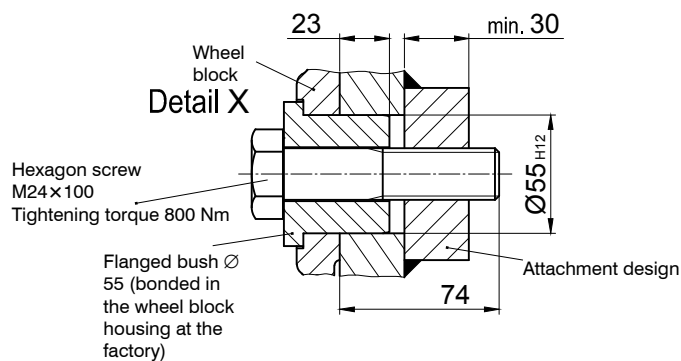

Blind hole $\varnothing 35$ H12 \times 20 deep with thread M 16

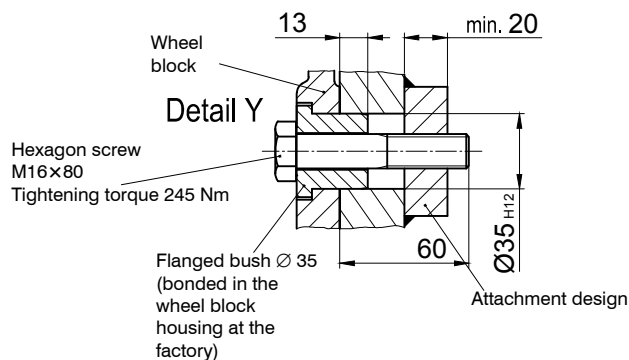

Wheel block RB 400

Drive shafts suitable for slip-on gear mechanisms from other manufacturers on request.

Single drive unit

Drive shaft suitable for slip-on gear mechanism with splined-shaft profile in accordance with DIN 5480

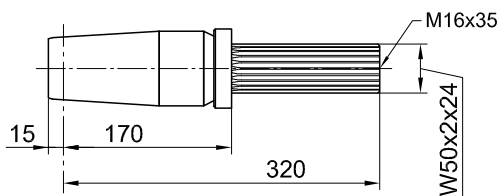
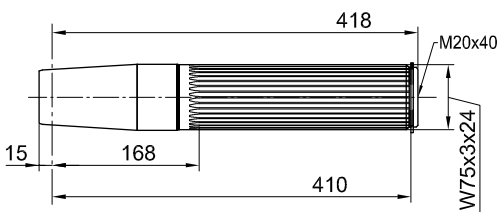
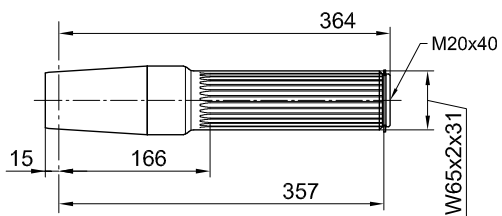
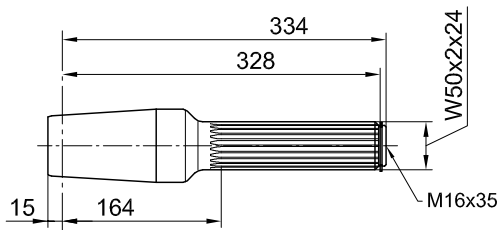

Slip-on gear mechanism		
Model	Manufacturer	Splined-shaft profile in acc. with DIN 5480

AUK 50	DEMAG	W50 x 2 x 24
--------	-------	--------------

AUK 60	DEMAG	W65 x 2 x 31
--------	-------	--------------

AUK 70	DEMAG	W75 x 3 x 24
--------	-------	--------------

F.A.T 68B	SIEMENS (FLENDER)	W50 x 2 x 24
KA.T 68		
CA.T 68		
K5..E	STÖBER	

Wheel block RB 400

Drive shafts suitable for slip-on gear mechanisms from other manufacturers on request.

Single drive unit

Drive shaft suitable for slip-on gear mechanism with splined-shaft profile in accordance with DIN 5480

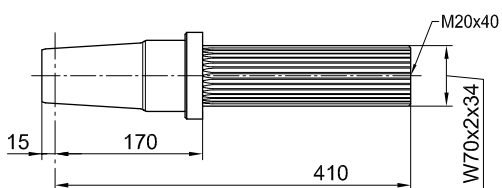
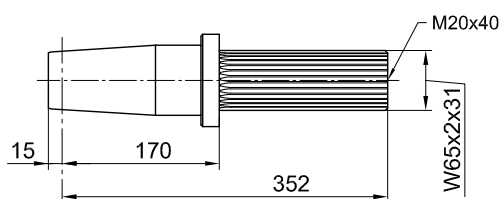
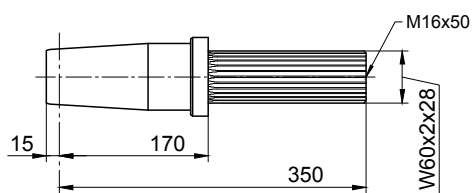
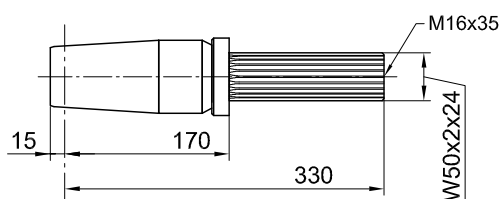

Slip-on gear mechanism		
Model	Manufacturer	Splined-shaft profile in acc. with DIN 5480
FV 77 / KV 77	SEW	W50 x 2 x 24
SK 4282 EA	NORD	
SPZT / SKZT 46	PREMIUM STEPHAN	

F.A.T 88B	SIEMENS (FLENDER)	W60 x 2 x 28
KA.T 88		
CA.T 88		
SK 5282 EA	NORD	

FV 87 / KV 87	SEW	W65 x 2 x 31
SPZT / SKZT 56..	PREMIUM STEPHAN	

FV 97 / KV 97	SEW	W70 x 2 x 34
SK 6282 EA	NORD	
SPZT / SKZT 66..	PREMIUM STEPHAN	

Wheel block RB 400

Drive shafts suitable for slip-on gear mechanisms from other manufacturers on request.

Single drive unit

Drive shaft suitable for slip-on gear mechanism with feather key connection in accordance with DIN 6885

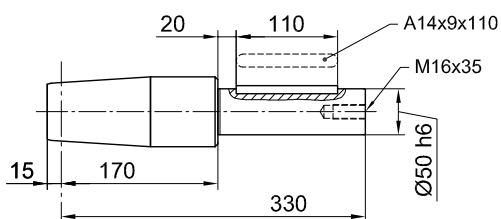
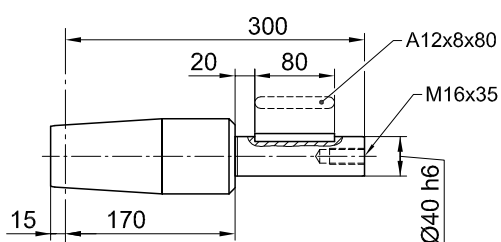

Slip-on gear mechanism		
Model	Manufacturer	Shaft journal

FA / KA 57 FA / KA / SA 67	SEW	Ø 40
SK 3282 AB	NORD	
FDA / FZA 68B KA / CA 68	SIEMENS (FLENDER)	
GFL 06 GKS 06 GSS 06	LENZE	
K4	STÖBER	
SPZH 36.. SKZH 36..	PREMIUM STEPHAN	

FA / KA / SA77	SEW	Ø 50
SK 4282 AB	NORD	
FDA / FZA 88B KA / CA 88	SIEMENS (FLENDER)	
GFL 07 GKS 07 GSS 07	LENZE	
K5 / K6	STÖBER	
SPZH 46.. SKZH 46..	PREMIUM STEPHAN	

Wheel block RB 400

Drive shafts suitable for slip-on gear mechanisms from other manufacturers on request.

Single drive unit

Drive shaft suitable for slip-on gear mechanism with feather key connection in accordance with DIN 6885

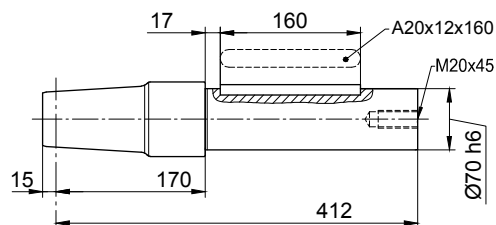
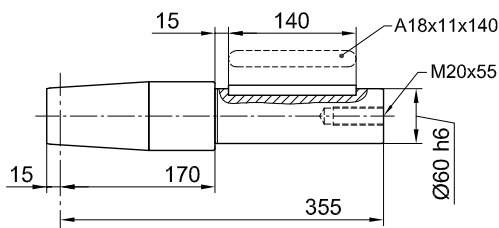

Slip-on gear mechanism		
Model	Manufacturer	Shaft journal

FA / KA / SA 87	SEW	Ø 60
SK 5282 AB	NORD	
FDA 108 B FZA 108 B KA 108	SIEMENS (FLENDER)	
GFL / GKS 09	LENZE	
K 7	STÖBER	
SPZH 56.. SKZH 56..	PREMIUM STEPHAN	

FA / KA / SA 97	SEW	Ø 70
SK 6282 AB	NORD	
FDA 128B FZA 128B KA 128	SIEMENS (FLENDER)	
SPZH 66.. SKZH 66..	PREMIUM STEPHAN	

Wheel block RB 400

Drive shafts suitable for slip-on gear mechanisms from other manufacturers on request.

Central drive unit

Both wheel blocks are driven with only one gear motor
(Splined-shaft profile, feather key connection and shrink disc attachment)

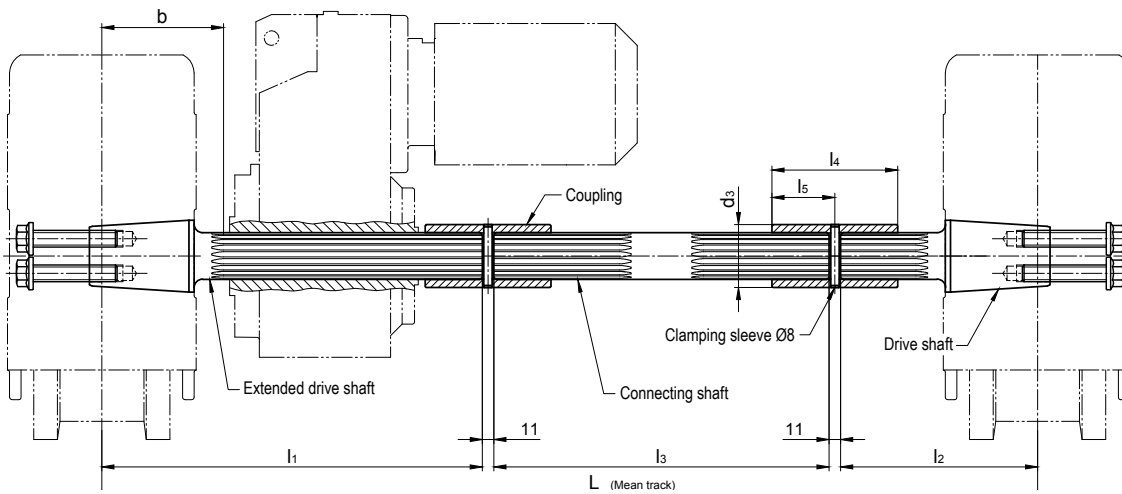

Model	Manufacturer	Splined-shaft-profile DIN 5480	L	l1	l2	l3	Centre RB to gearing b	l4	l5	d3	Clam- ping sleeve DIN 1481
AF 08 AUK 50	DEMAG	W50 x 2 x 24	For ordering, please provide	470	203	Dimensi- on L minus 695	130	120	60	65	8 x 65
FV 77 KV 77	SEW										
F.A.T 68B KA.T 68 CA.T 68	SIEMENS (FLENDER)										
SK 4282 EA SK 9032.1AZE A	NORD										
SPZT 46.. SKZT 46..	PREMIUM STEPHAN										
F.A.T 88B KA.T 88 CA.T 88	SIEMENS (FLENDER)	W60 x 2 x 28		490	203	Dimensi- on L minus 715	130	125	62,5	75	8 x 75
SK 5282EA	NORD	W65 x 2 x 31		490	203	Dimensi- on L minus 715	129	125	62,5	80	8 x 80
AF 10 AUK 60	DEMAG										
FV 87 KV 87	SEW										
SK 9042.1AZE A	NORD										
SPZT 56.. SKZT 56..	PREMIUM STEPHAN										
FV 97 KV 97	SEW	W70 x 2 x 34		555	213	Dimensi- on L minus 790	140	135	67,5	90	8 x 90
SK 6282EA SK 9052.1AZE A	NORD										
F.A.T 108B KA.T 108	SIEMENS (FLENDER)										
SPZT 66.. SKZT 66..	PREMIUM STEPHAN										

Wheel block RB 400

Drive shafts suitable for slip-on gear mechanisms from other manufacturers on request.

Central drive unit

Both wheel blocks are driven with only one gear motor
(Splined-shaft profile, feather key connection and shrink disc attachment)

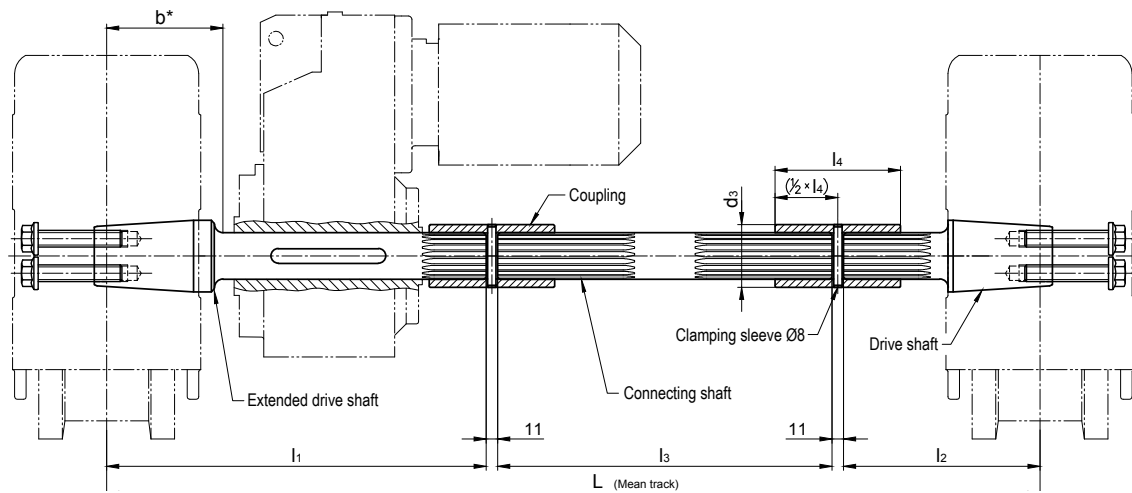

For gearboxes with hollow shaft and feather key connection in acc. with DIN 6885

Suitable for gearboxes with hollow shaft		L	I1	I2	I3	b* without gearbox stop	Feather key DIN 6885	Coupling Internal gearing/ d3 x l4
Inner-Ø	Length							
Ø 50	≤ 275 ¹⁾ ≤ 230 ²⁾	For ordering, please provide	470	203	Dimension L minus 695	125	A 14 x 9 x 110	N50 x 2 x 24 Ø 65 x 120
Ø 60	≤ 300 ¹⁾ ≤ 255 ²⁾		490	203	Dimension L minus 715	126	A 18 x 11 x 140	N50 x 2 x 24 Ø 65 x 120
Ø 70	≤ 350 ¹⁾ ≤ 310 ²⁾		555	203	Dimension L minus 780	130	A 20 x 12 x 160	N65 x 2 x 31 Ø 80 x 125

* Drive shafts without gearbox stop !

Dimension b = Smallest possible distance from the centre of the wheel block to the hollow drive shaft

¹⁾ at smallest possible distance of the gearbox (b)

²⁾ at distance of the gearbox = 170 mm

Drive shafts with gearbox stop on request.

Suitable for gearboxes of the following manufacturers:

Siemens Motox (Flender), Bauer (Danfoss), KEB, Lenze, Nord, PREMIUM STEPHAN, SEW, Siemens, Stöber, Demag

Et.al. suitable type designations, refer to the single drive unit.

Wheel block RB 400

Horizontal roller guide for wheels of $\varnothing 400$ (Form 1-5)

Horizontal roller guide with adjustable guide rollers made of 42CrMo4+QT.

The installation of a cellular plastic buffer (page 144) is possible without spacer discs. Parallel operating wheel blocks without horizontal roller guide can be installed with spacer discs for length compensation (see fig.).

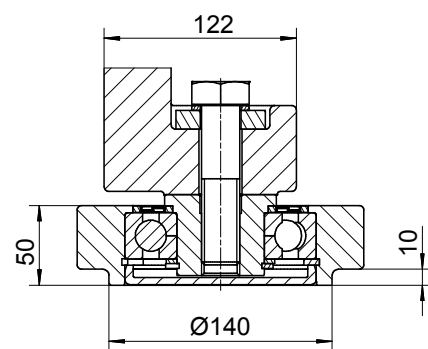
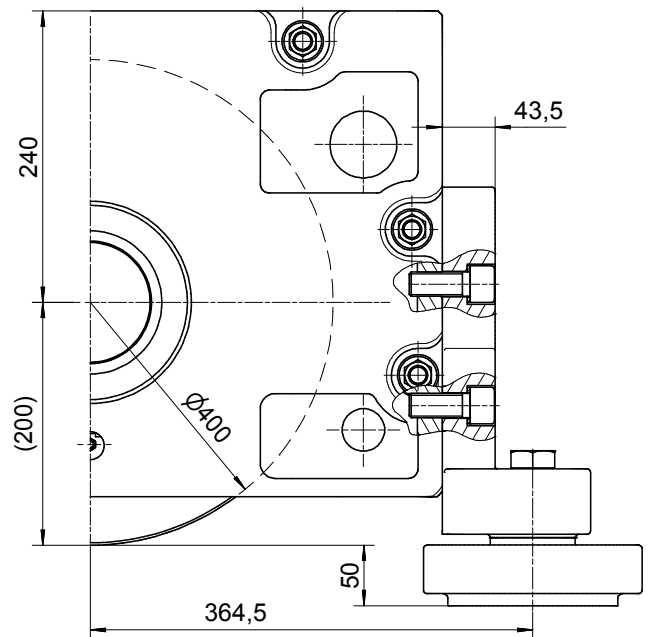
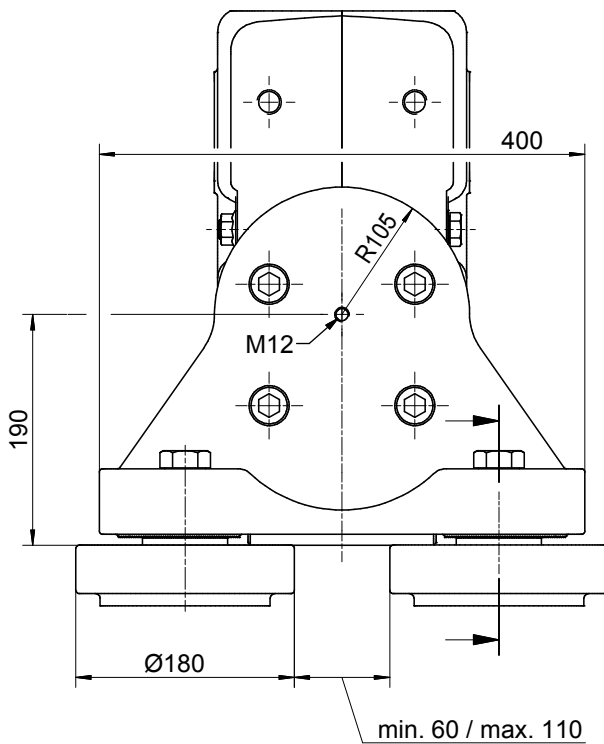

Acceptable horizontal load:
Max. 4500 kg
(As single part max. 6000 kg)

All necessary fastening elements are included in the scope of delivery.

Horizontal roller guide for other rail profiles are available on request.