

Driven- and Nondriven wheel sets with self aligning roller bearings

DIN 15 090

Rolling bearings series 222 and 223

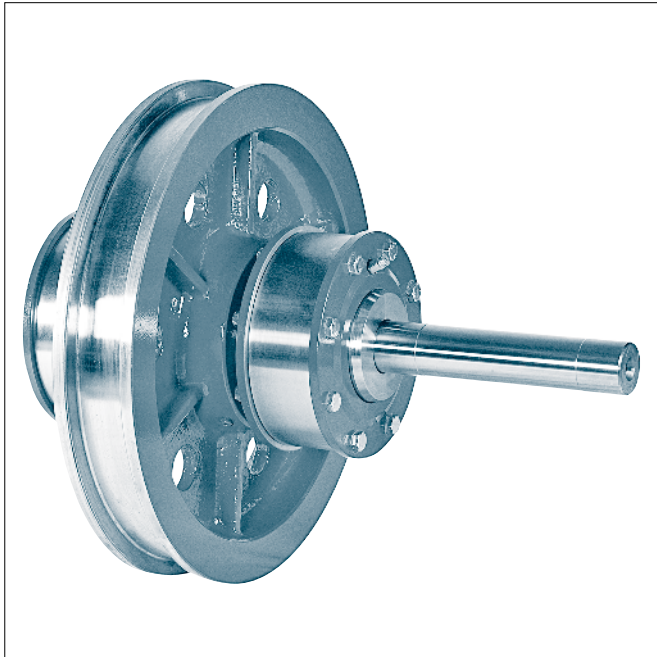

Driven wheel set Form SHKE

with casted crane wheel, drive shaft and suitable for gear unit with shrink disc.



Nondriven wheel set Form SHKE with casted crane wheel

Designation of a driven wheel set with narrow crane wheel (S), with wheel flanges (H), without bandage (K), without pressure oil feeding for the wheel (E), with crane wheel- $\varnothing d_1 = 630$ mm and width $b_1 = 110$ mm, self aligning roller bearings series 222:

Driven wheel set SHKE 630 × 110 - 222 DIN 15 090

To be stated with order:

- material for crane wheel and shaft
- anti friction bearings series 222 or 223
- design of driveshaft end (driven wheelset)

we deliver driven wheel sets with drive shaft suitable for all drive solutions (with connection flange, with clutch disc, with feather keyway acc. to DIN 6885-1, with splines acc. to DIN 5480 or in extended version for hollow shaft drive units with shrink disc).

Material:

Wheel body GE420 (GS-70) or
 G42CrMo4+QT (GS-42CrMo4 V)
Drive shaft,
shaft C45 N or
 C60 N or
 42CrMo4+QT

Other material and dimensions on request.

Driven wheel sets with shaft ends suitable for hollow shaft drive units of all manufacturers on request.

Form coding

coding letter	explanation
S	narrow crane wheel
B	broad crane wheel
H	crane wheel with wheel flanges
G	crane wheel without wheel flanges
M	crane wheel with Bandages
K	crane wheel without bandages
D	with pressure oil connection
E	without pressure oil connection

Driven- and Nondriven wheel sets with self aligning roller bearings

Rolling bearings series 222 and 223

DIN 15 090

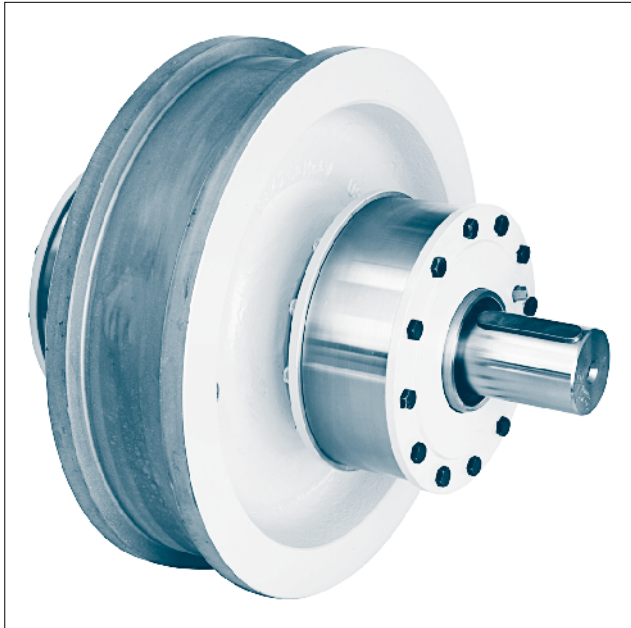

Driven wheel set Form BHKE

with drop forged crane wheel, drive shaft end suitable for hollow shaft drive unit with shrink disc.

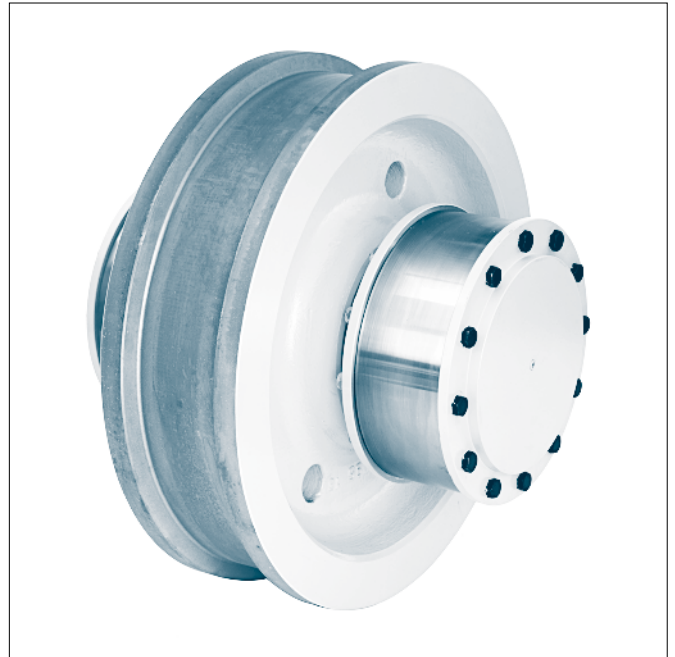

Driven wheel set Form BHKE

with drop forged crane wheel

Designation of a nondriven wheel set with broad crane wheel (B), without wheel flanges (G), with bandage (M), with pressure oil feeding for the wheel (D), with crane wheel- $\varnothing d_1=630$ mm and width $b_1=160$ mm, self aligning roller bearings series 222:

Nondriven wheel set BGMD 630 ×160 - 222 DIN 15 090

To be stated with order:

- material for crane wheel and shaft
- anti friction bearings series 222 or 223
- design of driveshaft end (driven wheelset)

we deliver driven wheel sets with drive shaft suitable for all drive solutions (with connection flange, with clutch disc, with feather keyway acc. to DIN 6885-1, with splines acc. to DIN 5480 or in extended version for hollow shaft drive units with shrink disc).

Material:

Wheel body	GE420 (GS-70) or G42CrMo4+QT (GS-42CrMo4 V)
Drive shaft, shaft	C45 N or C60 N or 42CrMo4+QT

Other material and dimensions on request.

Driven wheel sets with shaft ends suitable for hollow shaft drive units of all manufacturers on request.

Driven- and Nondriven wheel sets with self-aligning roller bearings

DIN 15 090

Rolling bearings series 222 and 223

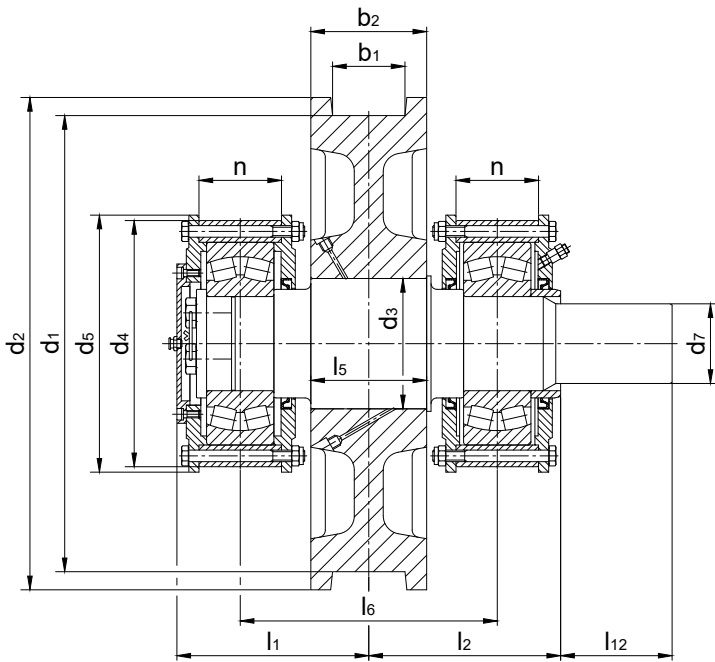

Driven wheel set Form BHKD

Driven wheel set with broad crane wheel, with wheel flanges, without bandage, with pressure oil feeding for the wheel, without connection flange, without shrink disc

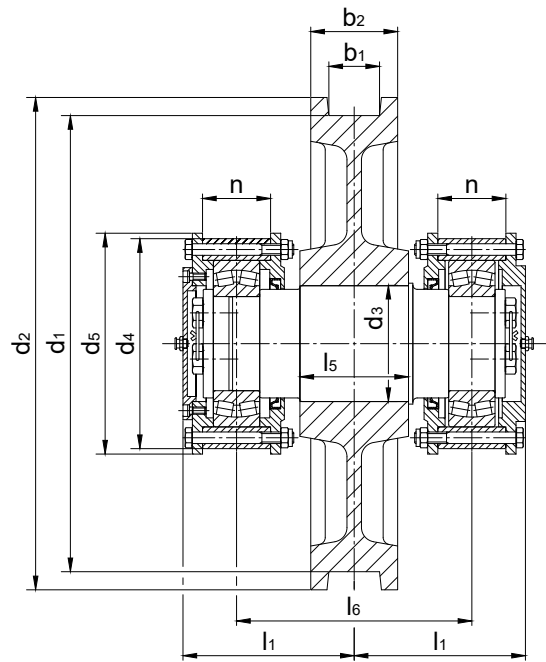

Nondriven wheel set Form SHKE

Nondriven wheel set with narrow crane wheel, with wheel flanges, without bandage, without pressure oil feeding for the wheel

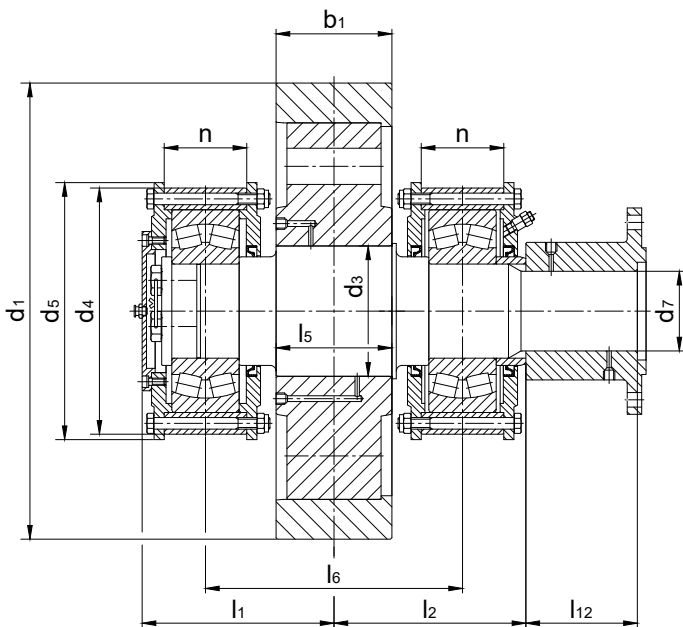

Driven wheel set Form BGMD

Driven wheel set with broad crane wheel, without wheel flanges, with bandage, with pressure oil feeding to the wheel, with connection flange for articulated shaft

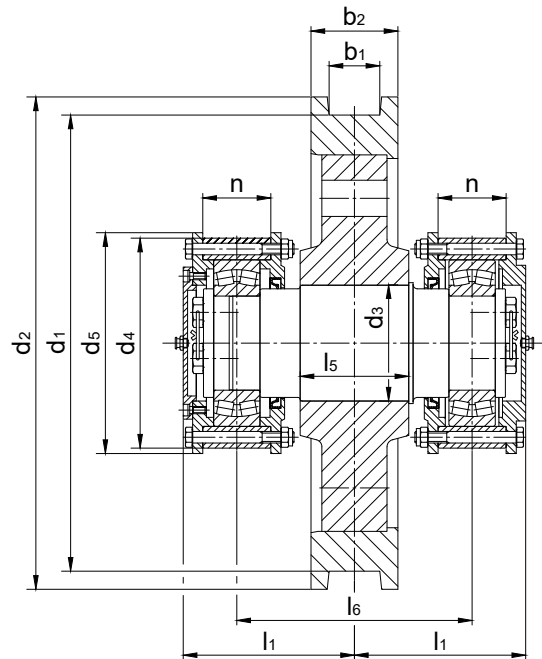

Nondriven wheel set Form SHME

Nondriven wheel set with narrow crane wheel, with wheel flanges, with bandage, without pressure oil feeding for the wheel

Driven- and Nondriven wheel sets with self aligning roller bearings

DIN 15 090

Rolling bearings series 222 and 223

Driven- and Nondriven wheel sets with anti friction bearings series 222

d ₁ h9	dimension and form									l ₁ a	l ₆	n +0,15 +0,05	bearings acc. to DIN 635-2	dimension (driven wheel sets)				
	Form ¹⁾	b ₁ ²⁾	b ₂	d ₂	d ₃	d ₄ h7	d ₅	d ₉ ³⁾	l ₅					l ₂	d ₇ ⁴⁾	l ₁₂	d ₇ ⁴⁾	l ₁₂
315	S	45-55	90	350	110	210	220	-	110	171	235	62	222 18	185	-	-	70	105
	B	55-65	110		120	230	240			173				222 20	190	70	105	80
400	S	55-65	110	440	120	230	240	310	140	188	265	72	222 20	205	70	105	80	120
	B	70-90	140		130	250	260			202				280	72	222 22	215	80
500	S	55-65	110	540	130	250	260	400	140	202	280	72	222 22	215	80	120	90	132
	B	70-90	140		140	265	275			210				290			82	222 24
630	S	65-75	120	680	160	290	305	520	150	237	325	94	222 26	250	-	-	100	152
	B	80-110	160		180	330	345		160	245	335			222 30	265	100	152	
710	S	75-90	140	760	170	310	325	590	180	249	350	94	222 28	260	100	152	110	152
	B	95-160	210		190	350	365		210	278	395			104	222 32		300	110
800	S	75-90	140	850	180	330	345	670	180	255	355	94	222 30	275	110	152	120	172
	B	95-160	210		200	370	385		210	289	405			114	222 34	310	130	172
900	S	75-90	140	950	190	350	365	760	190	268	375	104	222 32	290	-	-	130	172
	B	95-160	210		230	420	435		210	315	430			134	222 40	335	140	202
1000	S	75-90	140	1050	200	370	385	850	190	279	385	114	222 34	300	-	-	140	202
	B	95-160	210		250	480	500		210	332	450			146	222 44	355	160	202

Driven- and Nondriven wheel sets with anti friction bearings series 223

d ₁ h9	dimension and form									l ₁ a	l ₆	n +0,15 +0,05	bearings acc. to DIN 635-2	dimension (driven wheel sets)				
	Form ¹⁾	b ₁ ²⁾	b ₂	d ₂	d ₃ ³⁾	d ₄ h7	d ₅	d ₉ ⁴⁾	l ₅					l ₂	d ₇ ⁴⁾	l ₁₂	d ₇ ⁴⁾	l ₁₂
315	S	45-55	90	350	110	220	230	-	110	183	245	72	22316	185	-	-	70	105
	B	55-65	110		120	240	250			191				255	82	22318	190	70
400	S	55-65	110	440	120	240	250	310	140	206	285	82	22318	205	70	105	80	120
	B	70-90	140		130	265	275			216				295	92	22320	215	80
500	S	55-65	110	540	130	265	275	400	140	216	295	92	22320	215	80	120	90	132
	B	70-90	140		140	300	315			242				325			104	22322
630	S	65-75	120	680	160	300	315	520	150	247	335	104	22322	250	-	-	100	152
	B	80-110	160		180	340	355		160	265	355			114	22326	265	100	
710	S	75-90	140	760	170	320	335	590	180	259	360	104	22324	260	100	152	110	152
	B	95-160	210		190	360	375		210	300	415			124	22328	300	110	152
800	S	75-90	140	850	180	340	355	670	180	275	375	114	22326	275	110	152	120	172
	B	95-160	210		200	380	395		210	308	425			132	22330	310	130	172
900	S	75-90	140	950	190	360	375	760	190	290	395	124	22328	290	-	-	130	172
	B	95-160	210		230	420	435		210	325	440			144	22334	325	140	202
1000	S	75-90	140	1050	200	380	395	850	190	298	405	132	22330	300	-	-	140	202
	B	95-160	210		250	480	500		210	355	470			166	22338	355	160	202

1) S = narrow crane wheel B = broad crane wheel.

2) The dimension of the gauge recess b₁ to be stated with order.

3) Bandages and shrink-joint acc. to DIN 15 083.

4) Tolerance for d₇ acc. to DIN 15 091

5) Series 2 conform with the correlation of the articulated shafts acc. to DIN 15450

Driven- and Nondriven wheel sets with self aligning roller bearings

DIN 15 090

Rolling bearings series 222 and 223

Weight of the wheel sets, driven and nondriven with self aligning roller bearings series 222

d ₁	crane wheel	weight ²⁾ in kg							
	form ¹⁾	driven wheel set ³⁾				nondriven wheel set ³⁾			
h ₉		HK	HM	GK	GM	HK	HM	GK	GM
315	S	100	-	-	-	95	-	-	-
	B	123	-	-	-	117	-	-	-
400	S	153	172	-	-	147	166	-	-
	B	192	221	182	206	183	212	173	197
500	S	212	237	-	-	203	228	-	-
	B	263	303	251	288	253	293	241	278
630	S	356	398	-	-	344	386	-	-
	B	465	537	449	612	450	522	434	497
710	S	474	522	-	-	459	507	-	-
	B	683	791	661	766	658	766	636	741
800	S	579	633	-	-	559	613	-	-
	B	841	974	815	944	809	942	783	912
900	S	693	780	-	-	668	755	-	-
	B	1094	1265	1065	1220	1055	1223	1023	1181
1000	S	865	936	-	-	832	903	-	-
	B	1399	1602	1373	1552	1345	1542	1313	1492

Weight of the wheel sets, driven and nondriven with self aligning roller bearings series 223

d ₁	crane wheel	weight ²⁾ in kg							
	form ¹⁾	driven wheel set ³⁾				nondriven wheel set ³⁾			
h ₉		HK	HM	GK	GM	HK	HM	GK	GM
315	S	107	-	-	-	105	-	-	-
	B	137	-	-	-	132	-	-	-
400	S	166	185	-	-	161	180	-	-
	B	214	243	174	228	207	236	197	221
500	S	234	259	-	-	227	252	-	-
	B	311	351	299	236	301	341	259	326
630	S	369	411	-	-	359	401	-	-
	B	490	562	474	537	479	551	463	526
710	S	490	538	-	-	478	526	-	-
	B	695	803	673	778	675	783	653	758
800	S	606	660	-	-	576	670	-	-
	B	866	949	840	969	838	971	812	941
900	S	705	792	-	-	685	772	-	-
	B	1128	1299	1099	1254	1091	1262	1062	1217
1000	S	889	960	-	-	861	932	-	-
	B	1454	1651	1422	1601	1403	1600	1371	1550

1) S = narrow crane wheel B = broad crane wheel.

2) Die Gewichtsrechnung basiert on Reihe 2 der Wellenenden, without Anschlussflansch bzw. Kupplungsscheibe. Sie sind bezogen on b₁ max. and 50% bzw. 70% des Vollquerschnitts des Wheel bodys bei Crane wheelsn without bzw. with Bandages. Bei den Gewichtsangaben handelt es sich um Ungefährwerte; sie dienen nur der Orientierung and sind abhängig von der jeweiligen Type and dem angewandten Herstellverfahren der Crane wheels.

3) see Formverschlüsselung (S. 50)

Driven- and Nondriven wheel sets with self aligning roller bearings

DIN 15 090

Rolling bearings series 222 and 223

Bill of material

Lfd. Nr.	name	quantities for crane wheel- $\varnothing d_1$																								acc. to DIN resp. SEB ¹⁾					
		driven wheel set												nondriven wheel set																	
		315		400		500		630		710		800		900		1000		315		400		500		630			710		800		900
S	B	S	B	S	B	S	B	S	B	S	B	S	B	S	B	S	B	S	B	S	B	S	B	S	B	S	B	S	B	S	B
1	crane wheel	1												1												DIN 15 093					
2	shaft	1												1												DIN 15 091					
3	covers form A resp. B	1												1												DIN 15 092					
4	covers form C	-												1												DIN 15 092					
5	covers form D with short centering	1												1												DIN 15 092					
6	covers form D with short centering	1												1												DIN 15 092					
7	covers form E	1												-												DIN 15 092					
8	covers form F	1												1												DIN 15 092					
9	radial shaft seal rings A	3												2												DIN 3760					
10	bearing support	2												2												DIN 15 094					
11	self aligning roller bearings	2												2												DIN 635-2					
12	bush	1												-												DIN 15 095					
13	safety disc	1												2												DIN 15 095					
14	hexagonal screw	3												6												DIN EN ISO 4017 (DIN 933)					
15	safety wire	1												2																	
16	hexagonal screw	16	16	16	16	24	16	24	24	24	24	16	16	16	16	24	16	24	24	24	24	24	24	24	24	24	24	24	24	24	DIN EN ISO 4014 (DIN 931)
17	hexagonal nut	16	16	16	16	24	16	24	24	24	24	16	16	16	16	24	16	24	24	24	24	24	24	24	24	24	24	24	24	24	DIN EN ISO 4032 (DIN 934)
18	safety	32	32	32	32	48	32	48	48	48	48	32	32	32	32	48	32	48	48	48	48	48	48	48	48	48	48	48	48	48	(DIN 93)
19	cylinder screw	4	4	4	4	4	4	4	6	4	6	6	4	4	4	4	4	4	4	6	4	6	6	6	6	6	6	6	6	DIN 6912	
20	spring washer	4	4	4	4	4	4	4	6	4	6	6	4	4	4	4	4	4	4	6	4	6	6	6	6	6	6	6	6	DIN 7980	
21	screw plug G 1/4"	number of press oil-connections acc. to DIN 15 055 minus 1 (no screw plug for shaft on locating bearing)																								DIN 906					
22	connection nipple	1												-												DIN 15 095					
23	connection flange or shrink disc	1												-												DIN 15 452 SEB 601431					

1) Stahl-Eisen-Betriebsblätter des Vereins Deutscher Eisenhüttenleute